

BHARAT SANCHAR NIGAM LIMITED

(A Govt. of India Enterprise)

**GENERAL MANGER TELECOM DISTRICT BILASPUR SSA,
C.G. CIRCLE RAIPUR (CG)**

BID DOCUMENT

निविदा दस्तावेज

**E-TENDER FOR OFC MAINTENANCE IN MARWAHI-PENDRA
DISTRICT UNDER BILASPUR SSA.**

NIT No. W-1-1/NIT/Tender/GMTD-BIL/21-22/133 Dated 24.07.2021

Tender No. T-133/OFC-Mtc./Marwahi-Pendra/21-22/20 Dated 24.07.2021

READ THIS TENDER DOCUMENT THOROUGHLY

कृपया टेंडर डॉक्यूमेंट को ध्यान से पढ़ें

TENDER SUBMITTED THROUGH ONLINE WILL BE ACCEPTED

WEBSITE: [HTTPS://ETENDERS.GOV.IN](https://etenders.gov.in)

**NOTE: KINDLY SEE ALL CLARIFICATION / CORRIGENDUM ON WEBSITE & READ CAREFULLY BEFORE SUBMISSION
OF BID & ENSURE THAT ALL DOCUMENTS SUBMITTED ARE FULLY
AUTHENTICATED BY THE AUTHORIZED SIGNATORY**

**OFFICE OF THE GENERAL MANAGER TELECOM DISTRICT BILASPUR
BSNL BILASPUR SSA NEAR AGRASEN CHOWK BILASPUR (C.G.)**

07752-225900 EMAIL AGMBSP.NPCFA@GMAIL.COM

WEBSITE: [HTTP://CHHATTISGARH.BSNL.CO.IN](http://chhattisgarh.bsnl.co.in)

SECTION	CONTENT	PAGE NO
	QUALIFYING BID DOCUMENT	
I	Notice Inviting Tender	3-6
II	Bid Form	7
III	Bidder's Profile	8-10
IV-A	Instruction to Bidders	11-28
IV –B	E-tendering Instructions to Bidders	29
V	General (commercial) conditions of the contract	31-46
VI	Special conditions of the contract	47-56
VII	Scope of Work and jurisdiction of Contract	57-70
VIII	Engineering instruction for OFC Maintenance of	71-95
IX	Material Security Bond Form	96
IXA	Performance Guarantee Form	97-98
X	Agreement	99-100
XI	Letter of authorization for attending bid opening	101
XII	Power of attorney proforma	102
XIII	Rate of Empty Cable drums	103
XIVA	UNDERTAKING-I (No near Relative)	104
XIVB	UNDERTAKING-II(Non black listing of firm)	105
XIVC	PAYMENT INSULATION UNDERTAKING-III	106
XIVD	Understanding the terms and condition of Tender and Specification of work(Undertaking-IV)	107
XIVE	CLAUSE BY CLAUSE COMPLIANCE (UNDERTAKING-V)	108
	FINANCIAL BID	109
XV	Format for Financial Bid	110
		-111

सहा. महाप्रबंधक
 Asstt.General Manager (NP-CFA)
 O/o GMTD BSNL Near Agrasen Chowk
 Bilaspur (CG)



SECTION- I
Notice Inviting Tender

NIT No. W-1-1/NIT/Tender/GMTD-BIL/21-22/133

Dated – 24.07.2021

Tender No. T-133/Ofc-Mtc./Marwahi-Pendra/21-22/20

Dated - 24.07.2021

Digitally sealed tenders are invited by the General Manager, BSNL, Bilaspur for OFC maintenance work from the eligible bidders for the following area

S.No.	Section/Area	Estimated cost Rs	EMD	Cost of tender document	Last date of tender document submission	Date of tender opening
01	Marwahi-Pendra District	Rs 6,01,900.00	Rs 15,048/-	Rs 590/-	17.08.2021 up to 11.00 Hrs	18.08.2021 at 12.00 Hrs

Imp. Note

- (a) **EMD:-** The bidder may submit and sign **Bid Security Declaration** accepting that if they withdraw or modify their bids during period of validity etc., they will be suspended/debarred/banned for the period of one year.
- (b) **PSD:-** Performance Security is 3% of the value of contract (DoE OM No. 9/4/2020-PPD Dated – 12.11.2020)
- (c) The BSNL, at the time of award of work under the contract or during issue of work orders, reserves the right to decrease or increase the quantum of work without any change in the rates or other terms and conditions or withdraw tender at any stage as per requirement of BSNL. For this the decision of GMTD BSNL Bilaspur will be final however the individual item of works may varied in any quantum within the overall limit of +/- 25 % of the contracted value in terms of rupees or in physical terms as BSNL decides. The estimated cost given in NIT may vary depending on the actual works.

The bidding process will be accepted only through e-Tendering platform

- There is separate tender for each section of SSA. Bidder can participate in tenders of multiple section. 100% work will be awarded only to the L-1 bidder. If the offered rates of more than one bidder are same then work will be awarded to the bidder having more experience.
- Area of Work** : **(Details to be given).**
- Period of contract** : One Year from the date of agreement(extendable by one more year)
- Availability of e-Tender Document:** E-Tender document can be obtained by downloading it from the website <https://etenders.gov.in>.

The physical copy of the Tender document would not be available for sale. e-Tender documents will be available for downloading from **24.07.2021 onwards upto 17.00 Hrs of 17.08.2021 upto 11:00 Hrs.**

- 5 **MODE OF PAYMENT** (i): The Tender fee **in the event of downloading from website** should be paid in the form of Crossed Demand Draft / Bankers Cheque issued by any Nationalized /Scheduled Bank in favour of **“The AO (Cash), BSNL Bilaspur.**
OR
Can also be paid by cash payment to the Accounts Officer (Cash), at Cash Counter at - 2nd floor, Telephone Exchange Agrasen Chowk, Bilaspur between 11.00 hrs to 15.00 hrs on all working days. **Original Cash Receipt shall be produced.**
- (ii)The **Crossed Demand Draft/ Bankers Cheque** or Original Cash Receipt **should be submitted offline in the envelop as mentioned in clause 4.2 of Section-IV B**
- (iii)The **Tender fee is non-refundable & non-transferable.**
- 6 **MSE VENDORS** MSE/NSIC bidders registered for similar items may claim exemption from payment of cost of tender form, EMD /Bid Security. The bidder shall furnish along with the bid a certificate/documentary proof in respect of registration clearly showing its validity as on date of opening of the bid. Moreover, they should also produce documentary evidence showing that the firm is MSE/NSIC registered for the items tendered for. Failure to comply this provision shall result in summarily rejection of the bid.
- 7 **BID SECURITY / EMD** : The bidder shall furnish the bid Security / EMD in a following way:-
a)Demand Draft/ Banker’s cheque issued by any Nationalized /Scheduled Bank drawn in favor of “The Accounts Officer (Cash),BSNL Bilaspur OR Fixed Deposit Receipt”.
OR
b)Bank Guarantee from a Nationalized/scheduled bank drawn in favour of **“The A.O.(Cash), O/o the GMTD, BSNL, Bilaspur”** which should be valid for **180** days from the tender opening date.
(Refer Clause 8 of Section IV A)
- 8 Tender bids received after due time & date will not be accepted by the online system.
- 9 All documents submitted in the bid offer should be preferably in Hindi/English/Marathi. In case the certificate viz. experience, registration etc. is issued in any other language other than Hindi/English/Marathi, the bidder shall attach an English translation of the same duly attested by the bidder & the translator to be true copy in addition to the relevant certificate.
- 10 All documents should be digitally signed by the bidder/ **vendor BSNL.**
- 11 “The **GMTD, BSNL Bilaspur,** reserves the right to accept or reject any or all the bids without assigning any reasons whatsoever and he is not bound to accept the lowest tender rate.

12 TERMS AND CONDITIONS OF THE TENDER.

The tenders which are not submitted in above mentioned manner will be liable to be rejected.

12.1 During the entire evaluation process, if it is observed that the down loaded document is exactly not as per the original tender document and/or it is tempered/changed/ altered/modified in anyway, the bid will be liable to be rejected and a case of fraud will be registered with police.

12.2 **Eligibility Conditions:** For participation in tender (clause 4.1 & 4.2 of section IV B)

- i. The registration of the firm / Registration of Company
- ii. Blue ink signed Original/Attested **“Power of Attorney”** in case a person other than the Bidder has signed the tender document.
- iii. Latest Income Tax Return along with photo copy of PAN Card.
- iv. Labour license for any of ongoing works, and if not available at the time of bid submission, enclose a declaration letter mentioning that labour license will be obtained on award of contract within stipulated period.

v **Experience certificate:-** Firms having successfully completed similar works during last seven financial year and current financial years upto the date of NIT as follows:

i) Three similar successfully completed works costing not less than the amount equal to 40% of estimated cost put to tender.

OR

ii) Two similar successfully completed works costing not less than the amount equal to 60% of estimated cost put to tender.

OR

iii) One similar successfully completed works costing not less than the amount equal to 80% of estimated cost put to tender.

“Similar Works is defined as

The bidder must have an experience of executing works related to construction / maintenance of underground telecom cables, maintenance and installation of OFC cables in central/State Govt./PSU/Private Telecom service provider.

The experience certificate issued by clause 1 Officer/Group A officer or Circle project head/authorized signatory of private TSPs/ISPs in respect of works undertaken in BSNL/DOT/MTNL/Central/State Govt./PSU/Private Telecom Service Provider.

In case of private telecom service provider, experience certificate must be supported by copy of work orders and work completion certificates.

vi Turn over certificate : The turn over certificate issued by the chartered accountant. Average annual financial turnover should be minimum 30% of the estimated bid value of the area he is bidding for, in the tender in last three financial years.

vii Solvency certificate: from the banker of the Bidder for 40% of the estimated bid value of the area he is bidding for , in the tender . The solvency certificate shall not be older than One Year (OR Twelve months) from the date of issue of NIT.

Viii Copy of certificates of incorporation/copy of **Registration of firm**/copy of valid shop act License **OR** Copy of Partnership **deed** in case of partnership firm **OR** Copy of **Memorandum and Article of Association** in case of limited company

ix. Valid **EPF** registration certificate.

x. **Valid ESIC registration certificate , If not available at the time of bid submission enclose declaration letter** that it will be submitted at the time of agreement failing which EMD can be forfeited and party can be black listed from any tender in BSNL.

xi. Valid GST registration.

xii. Declaration regarding.

(1) Near relatives (declaration-I) (2) Black listing of firm(declaration-II)
(3) Payment insulation undertaking (undertaking –III)(4) under taking and declaration for understanding the terms and conditions of tender & specification of works (Undertaking –IV)

- xiii. MSME/NSIC certificate: Current and valid certificate
- xiv. List of all board of directors/partner, if applicable.
- xv. Registration certificate / Acknowledgement of entrepreneurs memorandum issued by State Director of Industries or from secretariat for industrial assistance (SIA), ministry of Industries, Government of India, if applicable.
- xvi. Clause by clause compliance / statement of deviation if any to the clauses of the tender document signed by the authorized signatory on letter head of the firm as per annexure
- xvii. Undertaking for having Splicing machine, OTDR and Power meter must be submitted with make/model with serial no. unique for each NIT. Same Serial Number of above said machines will not be considered for Other NIT of OFC Maintenance work of Bilaspur SSA.
- xviii. Copy of vehicle registration with RTO heaving insurance and commercial permit of at least **01 (One)** vehicle in the name of bidder/firm such as HTV/LCV.
- xix) Bid Cost & EMD
- xx) Scan copy of tender document
- xxi) Bid form and Tenderer profile

12.3 Contents of 2nd envelope (Financial bid/ BoQ) (to be submitted on line) Original price schedule (BoQ) in both PDF and .xls Format .

Note: (i) Scanned copies of all original documents/Notarised copies of all original documents mentioned above are to be uploaded with Digital Signature wherever applicable.

(ii) Submission of:

a) Offline documents listed in section IV-B, Clause 4.1 & online document clause 4.2 are mandatory.

b) Online documents, the bidder is expected to examine all instructions, forms terms and specifications in the bid documents and clarifications/ amendments/ addenda if any. Failure to furnish all Information required as per the bid documents or submission of the bids not substantially responsive to the bid documents in every respect will be at the bidder's risk and may result in rejection of bid.

(iii) If some document is not applicable for the bidder then he has to upload scanned copy of paper mentioning "The document < Name> called vide clause _____ is not applicable on us".

12.4 Offline submission:

The bidder shall submit the following documents offline to AGM (NP-CFA) O/o GMTD BSNL Bilaspur-495001 (Chhattisgarh). on or before the date & time of submission of bids specified in NIT, in a Sealed Envelope. **The envelope shall bear the tender name, the tender number and the words 'DO NOT OPEN BEFORE date & time).**

1 Tender Fee as per NIT (Original copy).

2 EMD-Bid Security (Original copy).

3 Original Power of Attorney (If applicable)

NOTE: The Bidder has to upload the SELF ATTESTED Scanned copy of all above said documents during Online Bid-Submission also.

The Bid, which is not accompanied by **the requisite bid security and cost of tender document**, shall be **summarily rejected**. Bid will not be accepted / received after expiry of schedule date and time.

The GENERAL MANAGER Telecom District Bilaspur reserves the right to reject any or all tenders without assigning any reason what-so-ever.

Bidders are instructed to examine worksite themselves at their own cost and quote accordingly.

AGM (NP-CFA)
O/o GMTD BSNL Bilaspur

SECTION –II
BID FORM

Tender No. T-133/OFC-Mtc./Marwahi-Pendra/21-22/20

Dated – 24.07.2021

Bid for tender enquiry No. -----

To,
A.G.M.(NP-CFA),
O/o G.M.T.D., Bilaspur

Dear Sir,

1. Having examined the above mentioned Tender Document , conditions of contract and specifications the receipt of which is hereby duly acknowledged, we, undersigned, offer to execute the work of **OFC Maintenance in Marwahi-Pendra District as per the engineering instructions** in conformity with said drawings, conditions of contract and specifications as may be ascertained in accordance with the schedule of prices attached herewith and made part of this Bid.
2. I/We undertake, if our Bid is accepted, we will execute the work in accordance with specifications, time limits & terms and conditions stipulated in the tender document.
3. If our Bid is accepted, we shall submit the securities as per the conditions mentioned in the contract.
4. I/We agree to abide by this Bid for a period of 180 days from the date fixed for Bid opening (Qualifying Bid) and it shall remain binding upon us and may be accepted at any time before the expiry of that period.
5. Until a formal Agreement is prepared and executed, this Bid together with your written acceptance thereof in your notification of award shall constitute a binding contract between us.
6. If our bid is accepted, we will provide you with a performance guarantee from a Nationalized/scheduled bank for a sum@ 3% of the contract value and material security guarantee from a Nationalized/scheduled bank for a sum of Rs.25,000 for the due performance of the contract.
7. Bid submitted by us is properly sealed and prepared so as to prevent any **subsequent alteration and replacement in Electronic format.**
8. **I/We understand that you are not bound to accept the lowest or any bid, you may receive.**

Date:-

Signature of the Bidder / Authorized Signatory.....
 Name of Bidder/ AuthorizedSignatory :-
 In Capacity of

***Note:-The Bidders are instructed to mention the appropriate area / s Nos. in the space provided in the form above.**

SECTION- III

Tenderer / Bidder’s Profile and Questionnaire

(To be filled in and submitted by the bidder)

sezis tropssaP
hpargotohp
dezirohtua/reddiB eht fo
Signatory holding
power of Attorney

**A) Tenderer’s Profile
General:**

1. Name of the Bidder/ firm
2. Name of the person submitting the Bid whose photograph is affixed
Shri/Smt.

(Bid shall be signed by the bidder or a person or persons duly "authorized to bind the bidder to the contract. The letter of authorization shall be indicated by written power-of-attorney accompanying the bid. Tenderer will submit the self attested copy of the PAN card / Election Commission I-Card / Passport of the proprietor or the authorized signatory in case of proprietor/ partner/ director is not signing the tender document. The tender is liable to be rejected if the signature and photograph do not match with the photograph affixed and the signature made in the tender documents. In case PAN card is not attached, copy of Income Tax Return should be submitted. Photograph and Signature of the authorized signatory should be duly attested by the proprietor or the partner/ Director.)

3. Address of the firm.....
.....
.....
.....
4. Telno. with STD code (O).....(FAX).....(R).....
Mobile No.....
Email Address.....
5. Registration and incorporation particulars of the firm:
 - i) Proprietorship
 - ii) Partnership
 - iii) Private Limited
 - iv) Public Limited

(Please attach self attested copies of documents of registration/ incorporation of your firm with the competent authority as required by business law)

6. Name of the Sole Proprietor/ Partners/ Director(s) of Pvt. Ltd Co.:-

S. No.	Name	Father’s Name	Designation
1.			
2.			
3.			
4.			
5.			
6			

7. Tenderer’s experience certificate details (if any) –

S. No.	Name of the department/ company, which has issued certificate	Name and Designation of certificate issuing authority	Telephone number of certificate issuing authority	Amount in Rs. as per certificate
			Total:	

(Self attested copy of the Experience Certificate may please be enclosed)

8 Bidder’s bank, its address and his current account number.....
 IFS Code.....

9 Permanent Income Tax No., Income Tax Circle.

(Please attach a copy of latest last income tax return).....

(Please give details in Sl. No. 10 to 14,)

10 GSTregistration no.

11 EPF Registration No.....

12 P- TAX Registration No.....

13 VAT/ TIN Registration No.....

14 ESI Registration No.....

15 Infrastructure capabilities:

i. Capacity of trenching per day (in meters)

ii. Capacity of pipe laying per day (in meters).....

iii. Capacity of pulling cable through duct/pipe per day (in meters).....

iv. Capacity of engaging mazdoors per day.....

v. Particulars of vehicles available with the Bidder

Type of Vehicle(s)

Registration number

.....
.....
.....
.....
.....

vi. Particulars of OTDR, PON OTDR, Splicing Machine, Power meter (normal & PON) possessed by the contractor which can help in fault restoration

.....

.....
.....

16 Details of Technical and supervisory Staff:

.....
.....
.....
.....
.....
.....
.....

B) Questionnaire

1. Do you think any other detail/ material is required to complete the work specified in the specification? Yes/ No.

1.1 If Yes, Give details

.....
.....
.....

2. Do you think any other item of work need be included in tender form to complete the work specified in the specification? Yes/ No.

2.1 If Yes, Give details

.....
.....
.....

3. Suggestion for improvement of the tender document.

.....
.....
.....
.....
.....

I/We hereby declare that the information furnished above is true and correct.

Place.....

Signature of Bidder/Authorized signatory.....

Name of the Bidder.....

Date.....

Seal of the Bidder

Note:- All information should be filled by the contractor

End of Section-III

SECTION IV- A
Instruction to Bidders

A. INTRODUCTION :

1. DEFINITIONS

a. **President of India:** The President of India means the President of India and his successors.

b.(a) **BSNL** : The Bharat Sanchar Nigam Limited.

b.(b) **BBNL** : Bharat Broadband Network Limited.

b.(c) **NOFN** : National Optical Fiber Network.

b.(d) **MOU** : Shall mean the Memorandum of Understanding herein containing the terms & conditions set forth & agreed therein, including all other documents expressly annexed thereto or incorporated therein.

c. **BSNL** : The BSNL means the BSNL, which invites the tenders on behalf of and its following officers.

- Chief General Manager
- General Manager
- General Manager
- Deputy General Manager/Area manager/ Director / Telecom Distt. Manager/
- Divisional Engineer/Divisional Engineer (Projects)
- Sub Divisional Engineer
- Junior Telecom Officer
- Chief Accounts Officer
- Accounts Officer
- Assistant Accounts Officer
- Junior Accounts Officer

including other officers in the BSNL, whatever designations assigned to them from time to time, who may be the in-charge of direction, supervision, testing, acceptance and maintenance including their successor(s) in the office appearing in various clauses shall be taken to mean the BSNL under the Ministry of Communications, BSNL of India.

d. **The GMTD, Bilaspur** means the Head of Bilaspur SSA and his successors.

e. **The jurisdiction of the GMTD, Bilaspur:** The jurisdiction of the GMTD, Bilaspur means Bilaspur Telecom District which coincides geographically with revenue District of Bilaspur SSA.

f. **Representative of the GMTD, Bilaspur:** Representative of the GMTD, Bilaspur means Officer and staff for the time being in "Bilaspur" deputed by the GMTD, Bilaspur SSA for inspecting or supervising the work or testing etc.

g. **Engineer - in - charge:** The Engineer - in - charge means the Engineering Officer nominated by the BSNL to supervise the work, under the contract.

- h. **Site Engineer:** Site Engineer shall mean as Jr Engineer/JTO/SDE of the BSNL who may be placed by the GMTD, Bilaspur/Director (Projects) as in charge of the work at site at any particular period of time.
- i. **A/T Unit :** A/T Unit shall be mean Acceptance and Testing unit of the BSNL or authorized unit of .
- j. **A/T Officer:** An officer authorized by (GMTD, Bilaspur/ T&D office MP Circle/) to conduct A/T.
- k. **Contract :** The term contract means, the documents forming the tender and acceptance thereof and the formal agreement executed between the competent authority on behalf of the Bharat Sanchar Nigam Limited and the contractor, together with the documents referred to therein including these conditions, the specifications, designs, drawings and instructions issued from time to time, by the engineer in-charge and all these documents taken together shall be deemed to form one contract and shall be complementary to one another .In the contract, the following expressions shall, unless the context otherwise requires, have the meanings, hereby respectively assigned to them. The expression works or work shall unless there be something either in the subject or context repugnant to such construction, be construed and taken to mean the works by or by virtue of the contract contracted to be executed whether temporary or permanent, and whether original, altered, substituted or additional.
- l. **Contractor :** The contractor shall mean the individual, firm or company, whether incorporated or not, undertaking the works and shall include the legal personal representative of such individual or the persons composing such firm or company, or the successors of such firm or company and the permitted assignees of such individual, firm or company.
- m. **Work :** The expression "works" shall unless there be something either in the subject or context repugnant to such construction be construct and taken to mean the works by or by virtue of the contract contracted to be executed whether temporary or permanent and whether original altered, substituted or additional.
- n. **Schedule(s):** Schedule(s) referred to in these conditions shall mean the relevant schedule(s) or the standard schedule or rates mentioned in the document.
- o. **Site:** The site shall mean the land/or other places on, into or through which work is to be executed under the contract or any adjacent land, path or street through which, the work is to be executed under the contract or any adjacent land, path or street which may be allotted or used for the purpose of carrying out the contract.
- p. **Normal time or stipulated time:** Normal time or stipulated time means time specified in the work order to complete the work as per MTTR.
- q. **Extension of Time (EOT):** Extension of Time means the time granted by the BSNL to complete the work beyond the normal time or stipulated time.
- r. **Date / time of Commencement of Work:** Date / time of Commencement of Work means the date / time of actual commencement of work on the day from the date of issue of work order, whichever is earlier.

- s. **Due date/ time of completion:** Due date / time of completion shall be the date by which the work shall be completed at site including clearance of site as per MTTR specified.
- t. **Duration of completion of work:** the duration of completion of work or completion time shall be time specified in the work order plus extension of time granted, if any.
- u. **Excepted risk :** Excepted risk are risks due to war (whether declared or not), invasion, act of foreign enemies, hostilities, civil war, rebellion, revolution, insurrection, military or usurped power, any acts of BSNL damages from aircraft, acts of God, such as earthquake, lightening and unprecedented floods and other causes over which, the contractor has no control and the same having been accepted as such, by the Accepting Authority or causes solely due to use or occupation by the BSNL of the part of the work, in respect of which a certificate of completion has been issued.

2. ELIGIBILITY OF BIDDERS :

The invitation of bids is open to all eligible bidder as per their eligibility mentioned in NIT of this tender document.

3. BID DOCUMENTS:

3.1 The maintenance work to be carried out, machines/equipments goods required, bidding procedure and contract terms are prescribed in the Bid Documents. The Bid Documents include:

- 3.1.1 Qualifying Bid :
 - 3.1.1.1 Notice Inviting Tender.
 - 3.1.1.2 Bid Form
 - 3.1.1.3 Bidder's Profile
 - 3.1.1.4 Instruction to Bidders
 - 3.1.1.5 General (Commercial) Conditions of the contract
 - 3.1.1.6 Special Conditions of Contract
 - 3.1.1.7 Scope of Work and jurisdiction of the contract
 - 3.1.1.8 Engineering instruction for OF Cable maintenance Specifications
 - 3.1.1.9 Material Security Bond Form.
 - 3.1.1.10 Agreement (Sample)
 - 3.1.1.11 Letter of Authorization for attending Bid Opening
 - 3.1.1.12 List of Documents to be submitted along with the Qualifying bid.
 - 3.1.1.13 Rates of Empty Cable Drums.

3.1.2 Financial Bid

3.1.2.1 Schedule of rates - for maintenance & construction

3.2 The Bidder is expected to examine all instructions, forms, terms and specifications in the bid documents. Failure to furnish all information required as per the Bid Documents or submission of bids not substantially responsive to the Bid Documents in every respect will be at the bidder's risk and shall result in rejection of the bid.

4. QUERIES ON BID DOCUMENTS:

A prospective bidder, requiring any clarification on the Bid Documents shall notify the BSNL Bilaspur in writing by FAX or by Email of the BSNL Bilaspur as indicated in the invitation of Bid (NIT). The BSNL Bilaspur shall respond in writing to any request for the clarification of the Bid Documents, which it receives

10 days prior to the date of opening of the Tenders. Copies of the query (without identifying the source) and clarifications by the BSNL Bilaspur shall be posted on website <https://etenders.gov.in> & www.chhattisgarh.bsnl.co.in for information of bidders.

4.1 Any clarification issued by BSNL in response to query raised by prospective bidders shall form an integral part of bid documents and shall amount to an amendment of the relevant clauses of the bid documents.

5. AMENDMENT OF BID DOCUMENTS:

5.1 The BSNL Bilaspur may, for any reason, whether at its own initiative or in response to a clarification requested by a prospective bidder, may modify bid documents by amendments prior to the date of submission of Bids with due notification to prospective bidders.

5.2 The amendments shall be posted on e-tendering portal (<https://etenders.gov.in> & www.chhattisgarh.bsnl.co.in to all prospective bidders and these amendments will be binding on them.

5.3 In order to afford prospective bidders a reasonable time to take the amendment into account in preparing their bids, the BSNL Bilaspur may, at its discretion, extend the deadline for the submission of bids suitably.

C. PREPARATION OF BIDS

6. Cost of Bidding:

The bidder shall bear all costs associated with the preparation and submission of the bid. The BSNL, will in no case, be responsible or liable for these costs, regardless of the conduct or outcome of the bidding process.

**7. DOCUMENTS ESTABLISHING BIDDER'S ELIGIBILITY AND QUALIFICATIONS:
On line submission**

The bidder shall furnish, as part of his bid documents establishing the bidder's eligibility, the following documents:

- i. Bid Security in accordance to clause no. 8 & Bid Cost
 - ii. Successful bidder has to submit Tender document(s), in original, duly filled in and signed by Bidder or his authorized representative along with seal on each page before agreement signing. Scan copy in case of e tender
 - iii. The Authenticated copy of registration of the firm/Company.
 - iv. Authenticated copy of the partnership deed in case of partnership firm or Blue ink signed Original/Attested "**Power of Attorney**" in case a person other than the Bidder has signed the tender document
 - v. Latest Income Tax Return along with Authenticated copy of PAN Card.
 - vi. Labour license for any of ongoing works, and if not available at the time of bid submission or there are no ongoing works, enclose a declaration letter mentioning that labour license will be obtain on award of contract within stipulated period.
- vii. Experience:-** Firms having successfully completed similar works during last seven financial year and current financial years upto the date of NIT as follows:

i) Three similar successfully completed works costing not less than the amount equal to 40% of estimated cost put to tender.

OR

ii) Two similar successfully completed works costing not less than the amount equal to 60% of estimated cost put to tender.

OR

iii) One similar successfully completed works costing not less than the amount equal to 80% of estimated cost put to tender.

“Similar Works is defined as

The bidder must have an experience of executing works related to construction / maintenance of underground telecom cables, maintenance and installation of OFC cables in central/State Govt./PSU/Private Telecom service provider.

The experience certificate issued by clause 1 Officer/Group A officer or Circle project head/authorized signatory of private TSPs/ISPs in respect of works undertaken in BSNL/DOT/MTNL/Central/State Govt./PSU/Private Telecom Service Provider.

In case of private telecom service provider, experience certificate must be supported by copy of work orders and work completion certificates.

viii. Turn over certificate: The turn over certificate issued by the chartered accountant. Average annual financial turnover should be minimum 30% of the estimated bid value of The Area he is bidding for, in the tender in last three financial years.

ix Solvency certificate from the banker of the Bidder for 40% of the estimated bid value of the area he is bidding for , in the tender . The solvency certificate shall not be older than One Year (OR Twelve months) from the date of issue of NIT.

x. Authenticated copy of Valid EPF registration.

xi. Authenticated copy of Valid ESI registration. If not available at the time of bid submission enclose a declaration letter that it will be submitted at the time of agreement failing which EMD can be forfeited and party can be black listed from any tender in BSNL.

xii. Authenticated copy of Valid GST registration.

xiii. For firm registered with MSE:-

Copy of current MSE registration certificate valid on date of opening of bid showing that their firm is registered with MSE for the items tendered for.

xiv. Declaration regarding.

(1) Close relatives (declaration-I)

(2) Non black listing of firm (declaration-II)

(3) Payment insulation undertaking (undertaking –III)

(4) Under taking and declaration for understanding the terms and conditions of tender and specification of works (Undertaking –IV)

xv Bid Form, duly filled in, as per **SECTION II**.

Xvi Bidder's profile duly filled in, as per **SECTION III** of the tender document.

Xvii Clause by clause compliance as per Undertaking V as per section XIV-E.

xviii Undertaking for having Splicing machine, OTDR and Power meter must be submitted with make/model with serial no. unique for each NIT . Same Serial Number of above said machines will not be considered for Other NIT of OFC Maintenance work of Bilaspur SSA .

xix. Copy of vehicle registration with RTO heaving insurance and commercial permit of at least **01 (One)** vehicle in the name of bidder/firm such as HTV/LCV.

Note: (i) Scanned copies of all original documents/Notarised copies of all original documents mentioned above are to be uploaded with Digital Signature wherever applicable.

(ii) **If some document is not applicable for the bidder then he has to upload scanned copy of paper mentioning “The document < Name> called vide clause _____ is not applicable on us”**

(iii) Machine having same serial number will not be considered in other NIT of Ofc Mtc. Tender

8. BID SECURITY:

- 8.1 The bidder shall furnish, as part of his bid, a bid security (EMD) for the amounts shown in the NIT. No interest shall be paid by the BSNL on the bid security for any period, what so ever.
- 8.2 The bid security is required to protect the BSNL against the risk of bidders conduct, which would warrant the security's forfeiture, pursuant to para 8.7.
- 8.3 Bid Security shall be paid in the form of Crossed Demand Draft issued by a Nationalized/scheduled bank, drawn in favour of Accounts Officer (Cash), O/o GMTD Bilaspur, payable at Bilaspur. OR Bankers Cheque OR Fixed Deposit Receipt OR Bank Guarantee from any Nationalized/Scheduled Bank for the period of 180 days
- 8.4 A bid not secured in accordance with para 8.1 & 8.3 shall be rejected by the BSNL as non responsive.
- 8.5 The bid security of the unsuccessful bidder will be refunded as promptly as possible.
- 8.6 Bid security of successful bidder will be either refunded as per option or will be adjusted in to Performance Security. DD for the balance amount would be submitted by bidder. Incase bidder prefers to submit TDR/PBG then TDR/PBG will be taken for entire amount and Bid security will be refunded.

8.7 The bid security shall be forfeited:-

- 8.7.1 If a bidder withdraws his bid during the period of bid validity specified in the bid document or.
- 8.7.2 If the bidder makes any modifications in the terms and conditions of the tender before acceptance of the tender, which are not acceptable to the BSNL or.
- 8.7.3 In case bidder submit any false Experience certificate relating to experience or any other false document.
- 8.7.4 In case of a successful bidder, if the bidder fails:
i. to sign the agreement in accordance with clause 25 of Section IV.
ii. To furnish Material Security in accordance with clause 24.2 of Section IV.
- 8.7.5 If the bidder submitted false & forged certificate/documents

9. BID PRICES:

- 9.1 The bidder shall give the total composite price inclusive of all levies and taxes, packing, forwarding, freight and insurance in case of materials to be supplied and inclusive of all taxes and levis in case of works to be executed, **but exclusive of GST**. The contractor shall be responsible for transporting the materials, to be supplied by the BSNL (At the district Telecom Store) or otherwise to execute the work under the contract, to site at his/their own cost. The costs of transportation are subsumed in the standard schedule Rates and therefore no separate charges are payable on this account. The offer shall be firm in Indian Rupees.

- 9.2 Price shall be quoted by the bidder only in Financial Bid. Prices quoted at any other place shall not be considered.
- 9.3 The price quoted by the bidder shall remain fixed during the entire period of contract and shall not be subject to variation on any account. A bid submitted with an adjustable price quotation will be treated as non-responsive and rejected.
- 9.4 Discount, if any, offered by the bidders shall not be considered unless they are specifically indicated in the schedule or rates (financial Bid). Bidders desiring to offer discount shall therefore modify their offers suitably while quoting and shall quote clearly net price taking all such factors like Discount, free supply, etc. into account.

10. PERIOD OF VALIDITY OF BIDS:

Bid shall remain valid for 180 days from date of opening of the bid (Qualifying Bid). A BID VALID FOR A SHORTER PERIOD SHALL BE REJECTED BY THE BSNL AS NON-RESPONSIVE.

11. SIGNING OF BID:

- 11.1 The bidder shall submit his bid, online complying all eligibility conditions, other terms and conditions of tender document to be read along with the verifications and amendments issued in this respect. All the documents must be authenticated, using Digital signature.
- 11.2 The bid shall contain no interlineations, erasures or overwriting except as necessary to correct errors made by the bidder in which case such corrections shall be signed by the person/ persons signing the bid .
- 11.3 **Power of Attorney:**
- (a) The power of Attorney should be submitted and executed on the non-judicial stamp paper (as per tender documents) of appropriate value as prevailing in the concerned states(s) and the same be **EITHER** attested by a Notary public **OR** registered before Sub-registrar of the state(s) concerned.
 - (b) The power of Attorney be executed by a person who has been authorized by the Board of Directors of the bidder in this regard, on behalf of the Company/ institution/ Body corporate. Copy of Board resolution / authorization shall also be submitted along with **POA**.
 - (c) In case of the bidder being a firm, the said Power of Attorney should be executed by all the partner(s) in favor of the said Attorney.
 - (d) Attestation of the specimen signatures of such authorized signatory of the bid by the Company's/ firm's bankers shall be furnished. Name, designation, Phone number, mobile number, email address and postal address of the authorized signatory shall be provided.
- 11.4 In case of partnership firm considered for PO, prior approval in writing shall be obtained from the PO placing authority before making any changes in the constitution of the firm or transferring the business to another person or company.

D. SUBMISSION OF BIDS

12.0 SEALING AND MARKING OF BIDS :

- 12.1 The bid may be called under :-

Single Stage Bidding & two Electronic Envelope System.

The details of sealing & marking of bids in each case is given below:

The bidder shall submit his bid in two envelopes.

- The First electronic envelope will be named as **Techno-commercial bid** . This envelope will contain documents of bidders satisfying the eligibility / Technical & commercial conditions as per clause 7&10 with Bid security as per Clause 8
 - The second electronic envelope will be named as **Financial bid (BOQ)** containing Price Schedules as per Section- XV-B
- 12.2 (a) The envelope, containing Offline documents mentioned in clause 4.2 of Section-IV B shall be sealed properly by the bidder and addressed to:
- (b) The envelope shall bear **the name of the tender**, the **tender Number**, and the words ‘ **DO NOT OPEN BEFORE** ’due date-----& time-----
- (c)The envelope shall indicate **the name and complete postal address of the bidder** to enable the BSNL Bilaspur to return the envelope unopened in case it is declared "LATE".
- (d) The envelope containing all above offline documents shall be sealed properly by the bidder and shall be delivered on or before due Date & Time of submission of bid as specified in DNIT(Section-**I**) to above said address mentioned in clause 12.2(a)
- (e) The envelope should be deposited in the tender box available at the **O/o AGM (NP-CFA)**, the General Manager, Telecom District Bilaspur, Address of office *or* sent by Registered Post/Speed Post/Courier or delivered in person on the above mentioned address (in clause 12.2(a) above). The responsibility for ensuring that outstation envelope is delivered in time shall rest with the bidder. The BSNL Bilaspur shall not be responsible if the bids are delivered elsewhere.
- (f) Tender not submitted in above mentioned manner will be rejected
- (g) **Venue of Tender Opening:** The e-Tender will be opened online in the chamber of **AGM (NP-CFA)**, O/o the General Manager, Telecom District Bilaspur, address of office on date & time specified in DNIT.
If due to administrative reasons, the venue of Bid opening is changed, it will be displayed prominently at venue and notice board at ----- and also on web site <https://etenders.gov.in/e procure/app>
- 12.3 **If offline documents are not delivered up to date & time of submission of bid as specified in DNIT, the bid shall be rejected.**

13.0 SUBMISSION OF BIDS :

- 13.1. Bids must be submitted online on e-tender portal <https://etenders.gov.in/e procure/app> and offline (Bid document Cost, EMD, POA,) by the bidders at the address specified under clause 12.2 not later than given date & time of submission as specified in **NIT Section- I**
- 13.2 The BSNL Bilaspur may, at its discretion, extend this deadline for the submission of bids by amending the Bid Documents in accordance with clause 5 of this section in which case all rights and obligations of the BSNL Bilaspur and bidders previously subject to the deadline will thereafter be subjected to the extended deadline.

14.0 LATE BIDS:

No bid shall be accepted online either by e-Tender Portal or offline document by the BSNL Bilaspur after the specified deadline for submission of bids prescribed by the BSNL Bilaspur pursuant to clause 13

15 MODIFICATION AND WITHDRAWAL OF BIDS :

- 15.1 The bidder may modify, revise or withdraw his bid after submission prior to deadline prescribed for submission of bid.
- 15.2 The bidder's modification, revision or withdrawal shall have to be online and digitally authenticated as per clause 12.

15.3 Subject to clause 17 no bid shall be modified subsequent to the deadline for submission of bids.

E Bid Opening and Evaluation:

16.0 OPENING OF BIDS BY BSNL Bilaspur:

- 16.1 Offline envelope will be opened first & if mandatory documents are not in order then online bid will not be opened. The BSNL Bilaspur shall open bids online in the presence of the authorized representatives of bidders **physically present** who choose to attend, at time & date specified in NIT(Section-I) on due date. The bidder's representatives, who are present, shall sign in an attendance register. Authority letter to this effect shall be submitted by the authorized representatives of bidders before they are allowed to participate in bid opening (A Format is given in Section-XI).
- 16.2 Maximum 2 representatives of any bidder shall be authorized and permitted to attend the bid opening.
- 16.3 For sequence & procedural details of opening of Bid, please refer Clause-6 of Section-IV B
- 16.4 The date fixed for opening of bids, if subsequently declared holiday by the BSNL/ submission of Bid is not possible due to unavoidable circumstances, the bid will be opened on the following working day, time and venue remaining unaltered unless the revised date of opening of bids is notified before opening of tender.

17.0 CLARIFICATION OF BIDS :

- 17.1 To assist in the examination, evaluation and comparison of bids, the BSNL Bilaspur may, at its discretion ask the bidder for the clarification of its bid. The request for the clarification and the response shall be in writing. **However, no post bid clarification at the initiative of the bidder shall be entertained.**
- 17.2 If any of the documents, required to be submitted along with the technical bid is found wanting, the offer is liable to be rejected at that stage. However the BSNL Bilaspur at its discretion may call for any clarification regarding the bid document within a stipulated time period. In case of non compliance to such queries, the bid will be out rightly rejected without entertaining further correspondence in this regard

18. PRELIMINARY EVALUATION:

- 18.1 BSNL shall evaluate the bids to determine whether they are complete, whether any computational errors have been made, whether required sureties have been furnished, whether the documents have been properly signed and whether the bids are generally in order.
- 18.2 Arithmetical errors shall be rectified on the following basis. If there is a discrepancy between the unit price and total price that is obtained by multiplying the unit price and quantity, the unit price shall prevail and the total price shall be corrected by the purchaser.
- 18.3 If there is discrepancy between words and figures, the amount in words shall prevail. If the Contractor does not accept the correction of the errors, his bid shall be rejected.
- 18.4 Prior to the detailed evaluation, pursuant to clause 19, the BSNL will determine the substantial responsiveness of each bid to the bid document. For purpose of these clauses a substantially responsive bid is one which conforms to all the terms and conditions of the bid documents without deviations. The BSNL determination of bid's responsiveness is to be based on the contents of the bid itself without recourse to extrinsic evidence.

18.5 A bid, determined as substantially non responsive will be rejected by the BSNL and shall not subsequent to the bid opening be made responsive by the bidder by correction of the non-conformity.

18.6 The BSNL may waive any minor infirmity or non-conformity or irregularity in a bid which does not constitute a material deviation, provided such waiver does not prejudice or effect the relative ranking of the bidder.

19. CONTACTING THE BSNL :

19.1 No bidder shall try to influence the BSNL on any matter relating to its bid, from the time of bid opening till the time the contract is awarded.

19.2 Any effort by the bidder to modify his bid or influence the BSNL in the BSNL's bid evaluation, bid comparison or the contract award decisions shall result in the rejection of the bid.

20. EVALUATION AND COMPARISON OF SUBSTANTIALLY RESPONSIVE BIDS

20.1 The BSNL shall evaluate in detail and compare the bids previously determined to be substantially responsive pursuant to clause 18.

20.2 The evaluation and comparison of responsive bids shall be on total amount (**composite**) as quoted by the bidder and indicated in schedule of rates of the bid documents.

20.3 If the offered rates of more than one bidder are same then work will be awarded to the bidder having more experience.

21 BSNL'S RIGHT TO ACCEPT ANY BID AND TO REJECT ANY OR ALL BIDS

The BSNL reserves the right to accept or reject any bid and to annul the bidding process and reject all bids, at any time to award of contract without assigning any reason what so ever and without thereby incurring any liability to the affected bidder or bidders on the grounds for the BSNL's action.

22 BSNL'S RIGHT TO VARY QUANTUM OF WORK :

The GMTD BILASPUR, at the time of award of work under the contract or during contract period, reserves the right to decrease or increase the work by up to 25 % of the total quantum of work and tender cost specified in the schedule of requirements without any change in the rates or other terms and conditions. The period of tender also increase for another one year on mutual consent.

23. AWARD OF CONTRACT :

23.1 The BSNL shall consider award of contract only to those eligible bidders whose offers have been found technically, commercially and financially acceptable.

23.2. Work will be awarded to the successful L-1 bidder subjected to compliance with MSME act with respect to MSE bidder(s).

21.3The work against the tender is for one year's requirement and the terms and conditions of this tender shall be operative for a period of one year from the date of signing of agreement between the BSNL and the contractor. The contract can be extended for further one year on same terms & conditions.

24. ISSUE OF LETTER OF INTENT :

- 24.1 The issue of letter of intent shall constitute the intention of the BSNL to enter in to the contract with the bidder. Letter of intent will be issued as offer to the successful bidder.
- 24.2 The bidder shall within 15 days of issue of intent , give his acceptance along with **material security and performance security** in conformity with clause 5(i) **SECTION -V** , provided with the bid documents, failing which his EMD may be forfeited and bid is liable to be cancelled.

25. SIGNING OF AGREEMENT

- 25.1 The signing of agreement shall constitute the award of contract on the bidder. The agreement with the successful bidder shall be signed by the BSNL within a week of submission of material security as per clause 24.2 above.
- 25.2 (a) Bid security of successful bidder will be either refunded as per option or will be adjusted in to PBG provided the Bidder submits PBG of entire amount or submit DD for balance amount.
- (b) Incase bidder prefers to submit PBG then PBG will be taken for entire amount and EMD will be refunded.

26. ANNULMENT OF AWARD:

Failure of the successful bidder to comply with the requirement of clause 24 and 25 shall constitute sufficient ground for the annulment of the award and forfeiture of the bid security, in which event; the BSNL may award the work to any other bidder at the discretion of the BSNL or call for new bids.

27. Preferable Requirements:

Bidder & his supervisor be equipped with (i) BSNL Mobile phone, (ii) Identity card. The maintenance team shall have other operators mobile along with BSNL mobile.

28. If any innovative and creative alternative is devised by the SSA either on its own or as directed from above, which covers the scope of this tender in whole or in part, this tender/contract agreement can be terminated by GMTD Bilaspur after taking stock of the situation either immediately or at a future date to which contractor will not have any claim.

Appendix-1 to Section 4 Part A

S. No.	Defaults of the bidder / vendor.	Action to be taken
A	B	C
1(a)	Submitting fake / forged	i) Rejection of tender bid of respective Vendor.
	a) Bank Instruments with the bid to meet terms & condition of tender in respect of tender fee and/ or EMD;	ii) Banning of business for 3 years which implies barring further dealing with the vendor for procurement of Goods & Services including participation in future tenders invited by BSNL for 3 years from date of issue of banning order.
	b) Certificate for claiming exemption in respect of tender fee and/ or EMD;	iii) Termination/ Short Closure of PO/WO, if issued. This implies non-acceptance of further supplies / work & services except to make the already received material work/ complete work in hand.
	and detection of default at any stage from receipt of bids till award of APO/ issue of PO/WO.	
	Note 1:- However, in this case the performance guarantee if alright will not be forfeited.	
Note 2:- Payment for already received supplies/ completed work shall be made as per terms & conditions of PO/ WO.		
1(b)	Submitting fake / forged documents towards meeting eligibility criteria such as experience capability, supply proof, registration with Sales Tax, Income Tax departments etc and as supporting documents towards other terms & conditions with the bid to meet terms & condition of tender : <i>(i) If detection of default is prior to award of APO</i>	i) Rejection of Bid & ii) Forfeiture of EMD.
	<i>(ii) If detection of default after issue of APO but before receipt of PG/ SD (DD,BG etc.)</i>	i) Cancellation of APO , ii) Rejection of Bid & iii) Forfeiture of EMD.
S. No.	Defaults of the bidder / vendor.	Action to be taken
A	B	C
1(b) cont d.	<i>(iii) If detection of default after receipt of PG/ SD (DD,BG etc.) .</i>	i) Cancellation of APO ii) Rejection of Bid & iii) Forfeiture of PG/ SD. However on realization of PG/ SD amount, EMD, if not already released

		shall be returned.
	(iv) If <i>detection of default after issue of PO/ WO</i>	i) Termination/ Short Closure of PO/WO and Cancellation of APO ii) Rejection of Bid & iii) Forfeiture of PG/ SD. However on realization of PG/ SD amount, EMD, if not released shall be returned.
	Note 3:- However, settle bills for the material received in correct quantity and quality if pending items do not affect working or use of supplied items.	
	Note 4:- No further supplies are to be accepted except that required to make the already supplied items work.	
2	If vendor or his representative uses violent/ coercive means viz. Physical / Verbal means to threatens BSNL Executive / employees and/ or obstruct him from functioning in discharge of his duties & responsibilities for the following :	Banning of business for 3 years which implies Barring further dealing with the vendor for procurement of Goods & Services including participation in future tenders invited by BSNL for 3 years from date of issue of banning order.
	a) Obstructing functioning of tender opening executives of BSNL in receipt/ opening of tender bids from prospective Bidders, suppliers/ Contractors.	
	b) Obstructing/ Threatening other prospective bidders i.e. suppliers/ Contractors from entering the tender venue and/ or submitting their tender bid freely.	
3	Non-receipt of acceptance of APO/ AWO and SD/ PG by L-1 bidder within time period specified in APO/ AWO.	Forfeiture of EMD.

S. No.	Defaults of the bidder / vendor.	Action to be taken
A	B	C
4.1	Failure to supply and/ or Commission the equipment and /or execution of the work at all even in extended delivery schedules, if granted against PO/ WO.	i) Termination of PO/ WO. ii) Under take purchase/ work at the risk & cost of defaulting vendor. iii) Recover the excess charges if incurred from the PG/ SD and outstanding bills of the defaulting Vendor.
4.2	Failure to supply and/ or Commission the equipment and /or execution of the Work in full	i) Short Closure of PO/ WO to the quantity already received by and/ or commissioned in BSNL and/ or in

	even in extended delivery schedules, if granted against PO/ WO.	pipeline provided the same is usable and/or the Vendor promises to make it usable. ii) Under take purchase/ work for balance quantity at the risk & cost of defaulting vendor. iii) Recover the excess charges if incurred from the PG/ SD and outstanding bills of the defaulting Vendor.
5.1	The supplied equipment does not perform satisfactory in the field in accordance with the specifications mentioned in the PO/ WO/Contract.	i) If the material is not at all acceptable, then return the non-acceptable material (or its part) & recover its cost, if paid, from the o/s bills/ PG/ SD. OR ii) If the material is inducted in network & it is not possible to return it and/ or material is acceptable with degraded performance, the purchaser may determine the price for degraded equipment (Financial penalty = Price – price determined for degraded equipment) himself and/ or through a committee. Undertake recovery of financial penalty from outstanding dues of vendor including PG/ SD.
S. No.	Defaults of the bidder / vendor.	Action to be taken
A	B	C
5.2	Major quality problems (as established by a joint team / committee of User unit(s) and QA Circle) / performance problems and non-rectification of defects (based on reports of field units and QA circle).	i) If the material is not at all acceptable, then return the non-acceptable material (or its part) & recover its cost, if paid, from the o/s bills/ PG/ SD; OR ii) If the material is inducted in network & it is not possible to return it and/ or material is acceptable with degraded performance, the purchaser may determine the price for degraded equipment (Financial penalty = Price – price determined for degraded equipment) himself and/ or through a Committee. Undertake recovery of financial penalty from outstanding dues of vendor including PG/ SD;

		And iii) Withdrawal of TSEC/ IA issued by QA Circle.
6	Submission of claims to BSNL against a contract	i) Recovery of over payment from the outstanding dues of Vendor including EMD/ PG & SD etc. and by invoking 'Set off' clause 21 of Section 5 Part A or by any other legal tenable manner. ii) Banning of Business for 3 years from date of issue of banning order or till the date of recovery of over payment in full, whichever is later.
	(a) for amount already paid by BSNL .	
	(b) for Quantity in excess of that supplied by Vendor to BSNL.	
	c) for unit rate and/ or amount higher than that approved by BSNL for that purchase.	
	Note 5:- The claims may be submitted with or without collusion of BSNL Executive/ employees.	
Note 6:- This penalty will be imposed irrespective of the fact that payment is disbursed by BSNL or not.		
7	Network Security/ Safety/ Privacy:- If the vendor tampers with the hardware, software/ firmware or in any other way that	i) Termination of PO/ WO. ii) Banning of business for 3 years which implies barring further dealing with the vendor for procurement of Goods & Services including participation in future tenders invited by BSNL for 3 years from date of issue of banning order. iii) Recovery of any loss incurred on this account from the Vendor from its PG/ SD/ O/s bills etc.
	a) Adversely affects the normal working of BSNL equipment(s) and/ or any other TSP through BSNL.	

S. No.	Defaults of the bidder / vendor.	Action to be taken
A	B	C
7 con-td.	<p>b) Disrupts/ Sabotages functioning of the BSNL network equipments such as exchanges, BTS, BSC/ MSC, Control equipment including IN etc., transmission equipments but not limited to these elements and/ or any other TSP through BSNL.</p> <p>c) tampers with the billing related data/ invoicing/ account of the Customer/ User(s) of BSNL and/ or any other TSP(s).</p> <p>d) hacks the account of BSNL Customer for unauthorized use i.e. to threaten others/ spread improper news etc.</p> <p>e) undertakes any action that</p>	<p>(Continued from page 178)</p> <p>iv) Legal action will be initiated by BSNL against the Vendor if required.</p>

	affects/ endangers the security of India.	
8	If the vendor is declared bankrupt or insolvent or its financial position has become unsound and in case of a limited company, if it is wound up or it is liquidated.	<p>i) Termination/ Short Closure of the PO/ WO.</p> <p>ii) Settle bills for the quantity received in correct quantity and quality if pending items do not affect working or use of supplied items.</p> <p>iii) No further supplies are to be accepted except that required to make the already supplied items work.</p> <p>iv) In case of turnkey projects, If the material is commissioned and is usable without any degradation of performance, then settle bills for the acceptable equipment/ material (or its part).</p> <p>v) In case of turnkey projects, if the material is inducted in network & it is not possible to return it and/ or material is acceptable with degraded performance, the purchaser may determine the price for degraded equipment (Financial penalty = Price – price determined for degraded equipment) himself and/ or through a committee. (continues to page 173)</p>

S. No.	Defaults of the bidder / vendor.	Action to be taken
A	B	C
8 con-td.		Undertake recovery of financial penalty from outstanding dues of vendor including PG/ SD.
9	In the event of the vendor, its proprietor, Director(s), partner(s) is / are convicted by a Court of Law following prosecution for offences involving moral turpitude in relation to the business dealings.	<p>i) Termination/ Short Closure of the PO/ WO.</p> <p>ii) Settle bills for the material received in correct quantity and quality if pending items do not affect working or use of supplied items.</p> <p>iii) No further supplies are to be accepted except that required to make the already supplied items work.</p> <p>iv) In case of turnkey projects, If the material is commissioned and is usable without any degradation of performance, then settle bills for the acceptable equipment/ material (or its part).</p> <p>v) In case of turnkey projects, If the material is inducted in network & it is not possible to return it and/ or material is acceptable with degraded performance, the purchaser may determine the price for degraded equipment (Financial penalty = Price – price determined for degraded equipment) himself and/ or through a committee.</p> <p>Undertake recovery of financial penalty from outstanding dues of vendor including PG/ SD.</p>
10	If the vendor does not return/ refuses to return BSNL's dues:	i) Take action to appoint Arbitrator to adjudicate the dispute.
	a) in spite of order of Arbitrator.	<p>i) Termination of contract, if any.</p> <p>ii) Banning of business for 3 years which implies barring further dealing with the vendor for procurement of Goods & Services including participation in future tenders invited by BSNL from date of issue of banning order or till the date by which vendor clears the BSNL's dues, whichever is later.</p>
		(continues)

S No	Defaults of the bidder / vendor.	Action to be taken
A	B	C
10 con- td.		iii) Take legal recourse i.e. filing recovery suite in appropriate court.
	b) inspite of Court Orders.	i) Termination of contract, if any. ii) Banning of business for 3 years which implies barring further dealing with the vendor for procurement of Goods & Services including participation in future tenders invited by BSNL from date of issue of banning order or till the date by which vendor clears the BSNL's dues, whichever is later.
11	If the Central Bureau of Investigation/ Independent External Monitor (IEM) / Income Tax/ Sales Tax/ Excise / Custom Departments recommends such a course	Take Action as per the directions of CBI or concerned department.
12	The following cases may also be considered for Banning of business: (a) If there is strong justification for believing that the proprietor, manager, MD, Director, partner, employee or representative of the vendor/ supplier has been guilty of malpractices such as bribery, corruption, fraud, substitution of tenders, interpolation, misrepresentation with respect to the contract in question. (b) If the vendor/ supplier fails to execute a contract or fails to execute it satisfactorily beyond the provisions of Para 4.1 & 4.2. (c) If the vendor/ supplier fails to submit required documents/ information, where required. (d) Any other ground which in the opinion of BSNL is just and proper to order for banning of business dealing with a vendor/ supplier.	i) Banning of business for 3 years which implies Barring further dealing with the vendor for procurement of Goods & Services including participation in future tenders invited by BSNL for 3 years from date of issue of banning order.

Note 7: Banning of Business dealing order shall not have any effect on the existing/ ongoing works/ AMC / CAMC which will continue along with settlement of Bills.

E-TENDERING INSTRUCTIONS TO BIDDERS

Bidders are advised to follow the instructions given in <https://etenders.gov.in> and references/clauses applicable from time to time.

1. Tender Bidding Methodology:

Sealed Bid System – ‘Single Stage – Using Two Envelopes

Financial & Techno-commercial bids shall be submitted by the bidder at the same time.

2. Broad outline of activities from Bidders prospective:

1. Procure a Digital Signing Certificate (DSC) from CCA
2. Register on <https://etenders.gov.in> Portal
3. Create Users and assign roles on <https://etenders.gov.in>
4. Search and find Notice Inviting Tender (NIT) on <https://etenders.gov.in>
5. Download Official Copy of Tender Documents from <https://etenders.gov.in>
6. Bid-Submission on <https://etenders.gov.in>
: Prepare & arrange all document/paper for submission of bid online and offline.
7. Submission of offline documents in sealed envelope at AGM (NP-CFA), O/o GMTD BSNL Agrasen Chowk Bilaspur-495001 (Chhattisgarh) size of documents to be uploaded remains minimum. If required, documents may be scanned at lower resolutions say at 150 dpi. However it shall be sole responsibility of bidder that the uploaded documents remain legible.
- 8 Utmost care may be taken to name the files/documents to be uploaded on <https://etenders.gov.in>
- 9 It is advised that all the documents to be submitted are kept scanned or converted to PDF format in a separate folder on your computer before starting online submission. Financial bid may be downloaded and rates may be filled appropriately.

For participating in this tender online, the following instructions are to be read carefully. These instructions are supplemented with more detailed guidelines on the relevant screens of the <https://etenders.gov.in>

3. Digital Certificates

For integrity of data and its authenticity/ non-repudiation of electronic records, and be compliant with IT Act 2000, it is necessary for each user to have a Digital Certificate (DC). also referred to as Digital Signature Certificate (DSC), of Class 2 or above, issued by a Certifying Authority (CA) licensed by Controller of Certifying Authorities (CCA) [refer <http://www.cca.gov.in>].

4. Method for submission of bid documents

In this tender the bidder has to participate in <https://etenders.gov.in> e-tender portal online. Some documents are to be submitted physically offline.

4.1. Offline submission:

The bidder shall submit the following documents offline to AGM (NP-CFA) O/o GMTD BSNL Bilaspur-495001 (Chhattisgarh). on or before the date & time of submission of bids specified in NIT, in a Sealed Envelope. The envelope shall bear (the tender name), the tender number and the words 'DO NOT OPEN BEFORE date & time).

- 4 Tender Fee as per NIT (Original copy).
- 5 EMD-Bid Security (Original copy).
- 6 Original Power of Attorney (If applicable)

NOTE: The Bidder has to upload the SELF ATTESTED Scanned copy of all above said documents during Online Bid-Submission also.

4.2 Online submission: As per clause 12.2 of Section I of NIT.

S. No. Contents of 1st Envelope (Techno-Commercial Bid) & 2nd Envelope(Financial Bid/ BoQ) :- As per tender clause

Note:

(i) If some document is not applicable for the bidder then he has to upload scanned copy of paper mentioning 'The document <name> not applicable on us.

(ii) If document asked for contains more than one page then all those pages may be uploaded in one PDF file.

(iii) In case of e-tendering, in case the bidder is unable to upload any of the documents listed above, he may submit the same physically. However EMD & cost of tender document will be submitted in original in physical form

SECTION V

GENERAL (COMMERCIAL) CONDITIONS OF THE CONTRACT

1. **APPLICATION :**

The General conditions shall apply in contracts made by the BSNL for the execution of OF cable maintenance works.

2. **STANDARDS**

The works to be executed under the contract shall conform to the standards prescribed in the OF Cable construction & maintenance practices.

3. **PRICES:**

3.1 Prices charged by the Contractor for the works performed under the Contract shall not be higher from the prices quoted by the Contractor in his Bid.

3.2 Price once fixed will remain valid for the period of contract. Increase and decrease of taxes/duties will not affect the price during this period except GST.

4. **SUBCONTRACTS :**

The contractor shall not assign, sub contract or subject the whole or any part of the works covered by the contract, under any circumstance.

5. **SECURITY**

i. **Material Security :**

- a. **The successful Bidder including MSE bidder will have to deposit material security as mentioned in the Scope of Work, subject to a minimum of Rs 25000/- , for each section or suitably decided by BSNL as for work requirement in the form of bank guarantee (valid up to and including six months after, the period of the contract) from a Nationalized/scheduled bank and in the material security bond form provided in the bid document, SECTION-IX. Material Security can also be submitted in the form of Crossed Demand Draft drawn in favour of Accounts Officer (Cash) O/o The GMTD Bilaspur issued by a Nationalized/schedule bank and payable at Bilaspur. The material Security will be a non interest bearing deposit, for any period what so ever.**
- b. The contractor at any point of time will not be issued stores costing more than material security. If due to any reason more store has to be issued to the contractor, then the material security will be suitably enhanced. In this regard the decision of the GMTD Bilaspur shall be final and binding.
- c. Proceeds of the material security shall be payable to the BSNL as a compensation for any loss resulting from the contractor's failure to handle properly the material issued to him under the contract.
- d. The material security shall be released / refunded within a fortnight from the date of the payment of the last final bill of the work under the contract or final settlement of material account whichever is later on production of "no dues certificate" from "Engineer-in-charge".

ii. **PERFORMANCE SECURITY**

- a. The total amount of Performance Security Deposit including MSE shall be 3% of the contract value .The successful bidder will be required to submit PBG/TDR in the prescribed proforma within 15 days after receipt of LOI. In case bidder opts to adjust 2.5 % EMD against Performance Security, bidder has to submit balance 1% amount of Performance Security by DD. Performance Security in the form of Account Payee Demand Draft issued by a Nationalized/scheduled bank, drawn in favour of Accounts Officer (Cash), O/O GMTD Bilaspur, payable at Bilaspur OR Bankers Cheque shall also be acceptable.
 - b. The proceeds of the performance security shall be payable to the BSNL as compensation for any loss resulting from the contractor's failure to complete its obligations under the contract.
 - c. The performance security deposit shall be refunded after expiry of warranty period of last work executed provided there are no recoveries to be made arising out of poor quality of work, incomplete work and/or violation of any terms and conditions of the contract as stipulated in the bid document.
 - d. No interest will be paid to the contractor on the security deposit.
 - e. **Validity of Performance security:-** Validity period the performance security **in the form of** PBG/TDR should be up to **One year and Six Months**
 - f. MSD/PSD/SD shall be refunded after expiry of warranty period and after submission of NOC
- iii. SD :- 10% amount will be deducted from each bill

6. **ISSUE OF WORK ORDERS AND TIME LIMIT :**

- 6.1 The work order shall be issued so as to include all items of works for the **SECTION** allotted to the contractor as put in the NIT.
- 6.2 The work orders shall be issued by the Divisional Engineer in-charge.
- 6.3 If due to any reason partial work order is to be issued then the same shall be issued with the approval of an officer not below the rank of General Manager/ (SSA Head not below the rank of Director).

7. **EXTENSION OF THE TIME LIMIT :**

7.1 **General**

7.1.1

- 7.1.2 In as much as "the time being deemed to be the essence of contract", throughout the stipulated period of contract, the work is to be proceeded with all due diligence on the part of the contractor.

7.2 **Application for Extension of the Time and Sanction of Extension of Time (EOT):**

- 7.2.1 There may be some hindrances, other than covered under force major, while execution of work and in such cases the contractor shall apply in writing to the engineer-in-charge for extension of

OFC MTC. MARWAHI-PENDRA DISTRICT

time (EOT), on account of which he desires such extension The Engineer-incharge shall forward the request to the competent authority (an officer of the rank of JAG level in-charge with his detailed report and photocopy of the hindrance register,. The competent authority is empowered to grant extension of time for completion of work on certain conditions. He shall exercise such powers, if the following conditions are satisfied.

The application contains the ground(s), which hindered the contractor in execution of work.

- 7.2.1.2 The Engineer-in-charge is of the opinion that the grounds shown for extension of time are reasonable.
- 7.2.2 The competent authority shall consider the request keeping all the facts and circumstances in view and shall grant extension of time, if in his opinion, there are reasonable and sufficient grounds for granting such extension and the reasons for delay are not ascribable to the contractor.
- 7.2.3 The competent authority may also grant extension of time for completion of work in cases where reasons for delay are ascribable to the contractor, but such extension of time shall be with LD charges as per clause dealing with penalty for delays in execution of works. The extension of time with LD charges shall be issued under the signature of JAG level Telecom. Officer competent to grant the extension of time.
- 7.2.4 The competent authority shall grant EOT with time period for completion of work expressly mentioned. The sanction of the competent Authority of EOT shall be issued under the signature of the Engineer in-charge.
- 7.2.5 If the competent authority is of the opinion that the grounds shown by the contractors are not reasonable and sufficient and declines to grant the extension of time, the contractor cannot challenge the soundness of the opinion by reference to arbitration. The decision of the competent authority on period of extension of time or refusal for extension of time shall be final and binding on the contractor.
- 7.3 Grant of Extension of Time without Applications:

There are, at times, practical difficulties like non-availability of materials, reasons of which are ascribable to the BSNL. In such cases, the Engineer-in-charge with the approval of competent authority to sanction EOT, may issue extension of time suomoto without waiting for contractor to make an application for EOT. Entry of hindrances shall be made in the Hindrance Register. The BSNL will, however, not be liable to the contractor for any losses or damages, costs, charges or expenses that the contractor may in any way sustain/suffer due to delay in making the above available.

7.4 PERIODICITY OF AGREEMENT

The agreement will be normally for one year and can be extended on discretion of the competent authority for six month and further extension of six months can be given on mutual agreement. The period of agreement can be less than one year also which may be further extended on satisfactory performance. Extension will always be given on same rates and same terms and condition & of the tender

8. MEASUREMENT, INSPECTION, TESTING AND ACCEPTANCE TESTING

8.1 Measurement :

- 8.1.1 The measurement books are to be maintained by the officer in-charge of the work or his immediate engineering subordinate not below the rank of Junior Telecom Officer. The entry shall

be made in ink. No entry shall be erased. If a mistake is made, it should be corrected by crossing out the incorrect words or figures and inserting the corrections, the corrections thus made shall be initialed & dated by the officer concerned.

8.1.2 **Responsibility of testing and recording measurements:** The measurement of various items of work shall be taken and recorded in the measurement book issued with each work order. The measurement shall be taken and recorded by an officer not below the rank of Junior Telecom Officer, supervising the work. The Junior Telecom Officer/Sub Divisional Engineer, directly responsible for supervision of work, shall be responsible for accuracy of 100% of measurements. The Sub Divisional Engineer where Junior Telecom Officer is supervising officer shall be responsible for conducting test check of 50% of measurements. The Divisional Engineer shall be responsible for conducting test check of 10% of measurements. Supervisor in charge will take OTDR trace of fault restored cable to ensure that all fibers in joint are correctly spliced.

8.1.3 **Method of recording of nomenclature of items :** Complete nomenclature of items, as given in the agreement need not be reproduced in the measurement book for recording the measurements but corresponding Item Code as provided, shall be used.

8.1.4 **Method of measurements:** The measurements of the work shall be done for activity wise as and when the item of work is ready for measurement. The methods of measurement of various items are enumerated as under:

- **Measurement of depth of trenches**
Normally for fault restoration work trenching will be done along the existing route and SOR item is available for the same.

. In case of re-routing the measurement of depth shall be recorded at each point of measurement (POM) in the measurement book. The points of measurements shall be at a distance of 10 meters starting from 0 (Zero) Meter. For example, if the length of segment is 75 meters, the POMs shall be at 0 M, 10M, 20M, 30M, 40M, 50M, 60M, 70M. The last POM shall be at 75th M to be recorded against Residual POM.

The efforts required to excavate trenches is not proportionate especially with reference to depth. Therefore, normally the workers tend to dig shallow trenches. As standard depth of the trench is important for future life and protection of cables, this tendency has to be discouraged. In order to encourage the contractor to achieve best possible depth in the face of site constraints, the following scale of payment shall be applied for digging trenches of lesser depths, subject to condition that relaxation has been granted by the competent authority for lesser depths.

Payment for lesser depth

Payment to contractors will be based on Proportionate rate as per strata of achieved depth. Emphasis has to be given for achieving standard depth of 165 cms and depth relaxation in deserving cases as per competent authority approval should be given,.

- **Measurement of lengths and profiles of strata and protection.**
The measurements of length of trenches are on running meter basis, irrespective of type of soil encountered while digging. The length of trenches dug in different strata in a segment shall be measured and recorded item code wise in the measurement book. The segment length from POMs and total of item code wise length should match.
The type of protection provided (item code-wise) in a segment shall be recorded in the measurement book in the sheet provided for this purpose.

OFC MTC. MARWAHI-PENDRA DISTRICT

- **Measurement of length of cable** : The length of cables laid in trenches, through pipes and through ducts shall be measured by use of RODO Meter/Measuring Tape. The length should be cross verified with the marking of lengths on the cable. The lengths shall be recorded in sheet provided in the measurement book.
 - **Measurement of Number of Splices & Splices Loss.** The Contractor shall make splices for all the fibers at all the joints along the route he has under taken right from the termination at the Gram Panchayat up to the spur joints when the laid cable is be joined with an existing cable, as well as all the spur joints to be made along the route with other cables being laid by the contractor. The contractor shall record the no. of splices and the splice loss at each of the splices and other transmission parameters for the laid cable (end to end)
 - **Measurement of other items** . The measurement/numerical details of other items shall be recorded in the sheets provided for respective items viz.
 - Digging of joint pit and preparation of joint chamber along with its type i.e. Brick chamber or Pre Cast RCC type.
 - Fixing, Painting and sign writing of route/joint indicators
 - Termination of Cable in equipment room and no. of joints
- 8.1.5 The contractor shall sign all the measurement recorded in the measurement book. This will be considered as an acceptance by the contractor, of measurements recorded in the MB. In case contractor fails to attend at the measurements or fails to countersign or to record the difference within a week, than in any such events the measurements taken by Engineer-in-charge or by the subordinate as the case may be shall be final and binding on the contractor and the contractor shall have no right to dispute the same.
- 8.1.6 The Divisional Engineer before passing the bill for SECTION covered by each set of measurement may carry out test check by re-opening trench at as many locations as necessary as specified in document 'procedures for underground cable construction' and bills be passed only when he is personally satisfied of the correctness of entries in the "measurement Book" and also when he is satisfied of other aspects of the work as per the terms of the contract. The contractor shall provide the necessary assistance of labour for re-opening of trench for test check by the Divisional Engineer, Separate payment shall not be made to the contractor for excavation of such test checks; however such test pits shall not be more than 10% of the cable laying work.
- 8.1.7 Measurement of the work of cable pulling through pipe/duct will be taken equal to the length of the pipe/duct through which the cable has been pulled and not the total length of the cable pulled through pipe/duct.

8.2 Inspection, and Quality Control :

- 8.2.1 (a) 1. State of the art technology shall be used. Quality control through Acceptance Test (AT) shall be done by BSNL as per guidelines issued by from time to time. reserves the right to carry out sample checks. Shortcomings/deficiencies noted shall be attended by contractor within 15 days and intimated to BSNL/ for re verification.
2. Payment shall be linked to Acceptance Testing (AT).
 3. Quality will also be controlled through Project Management/BSNL.
 4. Contractor will ensure incorporation of sufficient safety clauses.

The Quality of Works : The importance of quality of Optical Fibre Cable Construction works cannot be over-emphasized . The quality and availability of long distance media and efficiency of the reliable media connectivity to exchanges depends up on quality of laying of Optical Fibre Cable. Further, the OF cables are vulnerable to damages due to work of other agencies.

- 8.2.1 (b) The quality of O.F. cable Plant depends upon the quality of individual items of work involved viz Depth of Cables laid, care while paying & laying, Protection, Jointing of Cables and Terminations in equipment room and at last but not the least on documentation of cable network. In order to ensure quality in Cable Construction Work, each component of work needs attention. The works shall be carried out strictly in accordance with specifications laid down to achieve the requisite quality aim.
- 8.2.2 It is imperative that the contractor(s) is/are fully conversant with the construction practices and shall be fully equipped to carry out the work in accordance with the specifications. The contractors are expected and bound to ensure quality in construction works in accordance with specifications laid down. The contractor shall engage adequate and experienced supervisors to

OFC MTC. MARWAHI-PENDRA DISTRICT

ensure that work are carried out as per specifications and with due diligence and in a professional manner. The contractors shall satisfy himself/themselves that the work conforms to the quality specifications before offering the same to A.T. Wing for Acceptance and Testing.

- 8.2.3 An assessment of extent of interest shown by the contractors in executing the works with requisite quality shall be recorded and used in evaluating the contractors' Performance Rating (CPR).
- 8.2.4 In addition to Acceptance Testing being carried out by A.T. Wing and supervision by Construction Officers, all works at all times shall be open to inspection of the BSNL. The contractors shall be bound, If called upon to do so, to offer the works for inspection without any extra payment.
- 8.2.5 Site Order Book : The site order book is one of the primary records to be maintained by the JTO/SDE supervising the work during the course of execution of works. The noting made by officers as well as contractors, will form as basis for operation of many contractual clauses. The contractor shall remove all the defects pointed out by the BSNL in the. Site order book. The site order book is to be maintained in the prescribed format. The contractor or their authorized representatives shall also be at liberty to note their difficulties etc. in these books. The site order books shall invariably be consulted at the time of making final payments to the contractor.

8.3 Testing and Acceptance Testing : If applicable

- 8.3.1 The work shall be deemed to have been completed only after the same has been accepted by the A.T. Officer. The contractor shall make test pits at the locations desired by A.T. Officer for conducting test checks without any extra payment . The contractor shall restore the pits after test measurements to its original shape. The contractor shall be responsible to provide test/measurement tools and testers for conducting various tests.
- 8.3.2 **Scope of Acceptance and Testing:** The purpose of acceptance and testing is to verify integrity of measurement and quality of work done. The A.T. Officer shall not be responsible for recording of measurements for the purpose of billing and contractual obligations. However if the measurements taking by A.T. Officer are found to be lesser than the measurement recorded by the officer responsible for recording the measurements. The measurement taken by A.T officer shall prevail without prejudice to any punitive action against the contractor as per provisions of the contract and the officer recording the measurements. The contractor shall be obligated to remove defects/deficiencies pointed out by the A.T. Officer without any additional cost to the BSNL.
- 8.3.3 **Offering the work for acceptance and testing:** The Sub Divisional Engineer responsible for construction, after having satisfied himself of completion of work ready for A.T., shall offer the work to A.T. Officer for conducting Acceptance and Testing. The work shall be offered for A.T. as soon as part of work is complete in all respects. The work against any work order can be offered for A.T. in a number of stages.
- 8.3.4 The contractor shall provide labour, if demanded by the A/T officer for digging of test pits and other necessary infrastructure for carrying out the A/T work. No extra payment will be made for the digging of test pit.

9. WARRANTY:

- 9.1 The contractor shall warrant that the material supplied for the work shall be new and free from all defects and faults in material, workmanship and manufacture and shall be of the highest grade and consistent with the established and generally accepted standards for materials of the type ordered and shall perform in full conformity with the specifications and drawings. The contractor shall be responsible for any defects that may develop under the conditions provided by the contract and under proper use, arising from faulty materials, design or workmanship such as corrosion of the equipment, inadequate quantity of materials etc. and shall remedy such defects at his own cost when called upon to do so by the BSNL who shall state in writing in what respect the stores are faulty. This warranty shall survive inspection or payment for and acceptance of goods, but shall

expire except in respect of complaints notified prior to such date, twelve months after the acceptance testing.

- 9.2 If it becomes necessary for the contractor to replace or renew any defective portion/portions of the material under this clause, the provisions of the clause shall apply to the portion/portions material so replaced or renewed or until and end of the above mentioned period of twelve months, whichever may be later. If any defect is not remedied within a reasonable time, as prescribed by the BSNL, the BSNL may proceed to do the work at the contractor's risk and costs, but without prejudice to any other rights which the BSNL may have against the contractor in respect of such defects.
- 9.3 The Cable joint shall be guaranteed for a period of ONE year from the date of closing of joint. In case of failure of the joint due to poor workmanship i.e. failure of joint without external damage, with in the stipulated period of guarantee the contractor shall repair the joint(s) at his own cost within 24 hours of informing him, failing which the BSNL may carry out the repairs and penalty equivalent to five times of the approved rate of the jointing work plus the cost of materials used shall be recovered from the contractor from his pending bill/SD or any amount due to him without prejudice to any other action as per terms and conditions of the tender. The cost of joining kit, supplied by the BSNL, so used to revive the joint shall be deducted from the running bills of the contractor pending for payment or from security if all bills have been settled.
- 9.4 Replacement under warranty clause shall be made by the contractor free of all charges at site including freight, insurance, cost of works and other incidental charges.

10. AUDIT AND TECHNICAL EXAMINATION :

- 10.1 BSNL shall have the right to cause an audit and technical examination of the work and the final bills of the contractor including all supporting vouchers, abstract etc. to be made after payment of the final bill and if as a result of such audit and technical examination any sum is found to have been overpaid in respect of any work done by the contractor under the contract or any work claimed by him to have been done by him under the contract and found not to have been executed, the contractor shall be liable to refund the amount of over payment and it shall be lawful for BSNL to recover the same from him in the manner prescribed in clause with the heading payment of bills (same chapter), or in any other manner legally permissible and if it is found that the contractor was paid less than what was due to him under it, the amount of such under payment shall be duly paid by BSNL to the contractor.
- 10.2 Provided that BSNL shall be entitled to recover any sum overpaid and the contractor shall be entitled to payment of any sum paid short where such payment have been agreed upon between the Divisional Engineer or his subordinate officer on one hand and the contractor on the other under any term of the contract permitting payment for work after assessment by the (the SSA Head/Director (Projects)) or his subordinate officer.
- 10.3 Any sum of money due and payable to the contractor (including security deposit returnable to him) under this contract may be appropriated by the BSNL for the payment of a sum of money arising or under any other contract made by the contractor with the BSNL.

11. PAYMENT TERMS :

11.1 Procedure for Preparation and settlement of bills :

- 11.1.1 Work order will be issued for entire area for all cable length notified. Contractor has to organize the work in such a way that in minimum cable laying maximum faults can be restored.

11.1.1.1 BILL PREPARATION AND SUBMISSION

The contractor shall prepare the bills in triplicate ensuring execution of work in its completeness as envisaged above correctness of rates and quantum of work and submit the bills to J.T.O/JTO/SDE in-charge of work. The bills shall be prepared accurately & as per tender conditions and as per measurements recorded for the maintenance work. For continuous trenching more than 200 mtrs depth A/T will required to be attached with the bill. The contractor should submit the bill within **30** days of following month for the completed work. The bill shall be prepared for all the items/measurements of the work involved in execution for maintenance of routes during the month. The contractor shall prepare the bill containing the following details.

- The bill for all the items/quantities as per Measurements at the approved rates
- Adjustment of performance security deposit and statutory taxes already recovered.
- Store reconciliation statement furnishing account of stores received against the work order and balance/returned to the designated Store godown as surplus with requisite verifications from store in-charge/JTO/SDE in-charge of work.
- Sets of bound documentation.
- **Scrutiny of bills by JTO/SDE(I/C)**
The JTO/SDE in-charge of work shall scrutinize the bill against the works entrusted and accord necessary certificates stating that the work has been executed satisfactorily in accordance with specifications and terms and conditions of the contract. The JTO/SDE shall verify the quantities of items of work with reference to measurements recorded in the measurement book (and also A/T reports if applicable, in case of any deviations noted by A/T officer). The JTO/SDE in-charge of work shall submit the bills, prepared by contractor along the documents as mentioned hereunder to the Divisional Engineer, in-charge of work.

Documents to be attached with bills

- Material reconciliation statement
- Measurement Book Xerox.
- A/T Certificates in case of capital nature of work. If applicable
- Certification by SDE/DE In-charge of work regarding RID updating in physical along with lat long of location in case of capital nature of work
- Third copy of the bill with photocopies of measurement sheets and A/T reports in case of capital nature of work. (Not for Payment)
- List showing the details of labours / employees engaged and duration of their engagement.
- Details of empty cable drums cost which needs to be recovered from the bill
- The amount of wages paid to such labours / Employees for the duration in question.
- Amount of EPF contributions (both employers and employees contribution) for the duration of engagement in question paid to the EPF authorities.
- Copies of authenticated documents of payment of such contribution to EPF authorities.
- Declaration regarding compliance of the EPF Act./ESI Act.. and other labour laws applicable from time to time.
- Details of recoveries/penalties for delays, damages to BSNL/Third party properties as per provisions of the contract. In case no recovery is to be made, NIL report needs to be submitted.

The Contractor may deposit the wages in the Bank account of the Workers through online as NEFT/RTGS, the deposit slip for the bank credit shall be attached to the bill

-
- **Submission of bills by JTO/SDE(I/C)**
The SDE in-charge of the work shall scrutinize bills and accord necessary certificates and submit the bills with the documents as mentioned below to the Divisional Engineer, in-charge of work.

- First copy of bill with first copies of measurement sheets of measurement book and A/T reports. (PAYABLE copy) and copy of work order
- Second copy of bill with second copies of measurement sheets of measurement book and A/T reports. (Not for Payment) and copy of work order

11.1.1.2 Processing & Certificate of bills by D.E (I/C)

The divisional Engineer I/C shall exercise the prescribed checks on the bills and accord necessary certificates on the bills. The Divisional Engineer shall retain the third copy in record and record it in the estimate file maintained in his office and send first and second copies with all documents to relevant higher office for processing of bills and release of payment.

- 11.1.1.3 The work section shall process the bills in the estimate file of the concerned work and scrutinize the bills vis-a-vis work order issued, sanctioned provisions in the estimate etc. The bill shall be passed after necessary scrutiny by Works section, by the officer competent to pass the bill. Against any bill, payment to the extent of only 90% shall be made which shall be treated as an advance to the contractor and Statutory taxes (Income Tax etc.) applicable to contract shall be deducted at the time of payment from each running bill. Payment for the amount passed in the bill will be released only after the contractor gives a stamped receipt for the amount, if the bills are not pre-receipted. Details of payment of all the bills shall be entered into contract's ledger by Work section of the Planning Cell.
- 11.1.1.4 The office cell shall also scrutinize the bill to recover all the liabilities of the contractor and statutory taxes. The bill shall be passed, after necessary scrutiny by Works section, by the officer competent to pass the bill.
- 11.1.1.5 Payment to the contractor will be made from one central point by the Circle office or SSA HQ to be decided.
- 11.1.1.6 All efforts will be made for payment of duly accepted completed bills within 2 to 3 months time.

11.2 Procedure for Payment for sub-standard works :

- 11.2.1 The contractors are required to execute all works satisfactorily and in accordance with the specifications. If certain items of work are executed with unsound, imperfect or unskilled workmanship or with materials of any inferior description or that any materials or articles provided by him for execution of work are unsound or of a quality inferior to that contracted for or otherwise not in accordance with the contract (referred to as substandard work hereinafter), the Divisional Engineer in-charge shall make a demand in writing specifying the work, materials or articles about which there is a complaint .
- 11.2.2 **Timely action by construction Officers:** Timely reporting and action, to a great extent can prevent occurrence of sub standard work, which will be difficult or impossible to rectify latter on. It is incumbent on the part of Construction Officers to point out the defects in work in time during progress of the work. The Junior Telecom Officer/sub Divisional Engineer responsible for execution and super vision of work shall without any loss of time submit a report of occurrence of any sub standard work to the Divisional Engineer in-charge besides making entry in the site order book. A notice in respect of defective work shall be given to the contractor by Divisional Engineer in-charge in writing during the progress of work asking the contractor to rectify/replace/remove the sub standard item of work and also definite time period within which such rectification/removal/replacement has to be done. After expiry of the notice period, if the contractor fails to rectify/replace/remove the sub standard items, the defects shall be got rectified/replaced / removed BSNL ally or through some other agency at the risk and cost of the contractor.
- 11.2.3 Non-reporting of the sub standard work in time on the part of Construction Officer (s) shall not in any way entitle the contractor to claim that the defects were not pointed out during execution and as such the contractor cannot be absolved of the responsibility for sub standard work and associated liabilities.

- 11.2.4 **Authority and Procedure to accept sub standard work and payment thereof:** There may be certain items of work pointed out as sub standard which may be difficult to rectify and in the opinion of the GMTDBilaspur, the items in question will not materially deteriorate the quality of service provided by the construction, the GMTDBilaspur, shall appoint committee to work out the reduced rates payable to the contractor for such sub standard work. The committee shall constitute one Divisional Engineer other than the one who is directly in-charge of cable Construction involving sub standard items of work, as Chairman and one JTO/SDE and an Accounts Officer as members. The committee shall take into account the approximate cost of material / work pointed out sub standard and recommend the rates payable for sub standard work which shall not exceed 60% of the approved rates of the items in question.
- 11.2.5 **Record of sub standard work:** The items adjudged as sub standard shall be entered into the measurement book with red ink.

DISPOSAL OF EMPTY CABLE DRUMS:

- 12.1 The contractor shall be responsible to dispose off the empty cable drums after laying of the cable. The competent authority taking in to account the prevailing market rates has fixed the cost of Optical Fiber cable drums. The cost of empty cable drums shall be deducted from the bill for the work on which the cable along with the drum has been issued or any other amount due to the contractor or from security deposit.
- 12.2 Rates fixed for Optical Fiber cable drums are given in Section- XIII of Tender Document (Qualifying Bid). The rates are fixed and there is no variation on these rates.
- 12.3 The contractor shall be responsible for the accounting of the cable drums issued and shall mention the number cable drums in the bill so that the amount is deducted from the bills due.
- 12.4 The contractor shall not be allowed to dump the empty cable drums in Govt./public place, which may cause inconvenience to Govt/Public. If the contractor does not dispose off the empty cable drums within 3 days of becoming empty, the BSNL is at liberty to dispose off the drum in any manner deemed fit and also recover the amount fixed in this contract for empty cable drums along with the transportation charges (to be decided by GMTDBilaspur from the bill/security deposit/any other amount due to the contractor.

13. PENALTY CLAUSE :

13.1. Delay in the contractors' performance

- 13.1.1 The time allowed for completion of the work as entered in the tender shall be strictly adhered by the contractor and shall be deemed to be the most important aspect of the contract on the part of the contractor. The work shall throughout the stipulated period of contract, be proceeded with all due diligence to achieve the desired progress uniformly, and the contractor shall pay as penalty
- 13.1.2 Penalty of Rs. 200/- for delay of each hours delay will be levied if fault is not restored within 8 hrs. Maximum penalty will be 10% of the cost of that fault restoration work.**
- 13.1.3 In case of undue delay by the contractor, BSNL reserves the right to get the fault restored at the risk & cost of the contractor.
- 13.1.4 If the permanent restoration work is not carried out within 48 hrs, without any specific reason, penalty of Rs. 500/- per day will be levied.
- 13.1.5 On any date the penalty payable as above, reaches 10 (ten) percent of the estimated cost of the work, the contractor should proceed with the work further only on getting a written instructions from the Divisional Engineer that, he is allowed to proceed further with the work. It will be in the

discretion of the Divisional Engineer to allow the contractor to continue with the work on the basis of any written agreement reached between the contractor and the Divisional Engineer on one of the conditions of such agreement may be a stipulation for the contractor to agree for realization of penalty for delay at a higher rate as may be agreed between the Divisional Engineer and contractor.

13.1.6 Penalty for delay in completion of the work shall be recoverable from the bills of the contractor and/or by adjustment from the security deposit or from the bills of any other contract. However, adjustment from security deposit will be made only when the contract has been terminated or at the time of final settlement of bills on completion of work.

13.1.7. Since this damage naturally arise in the usual course of things from the breach of contract when the contractor and the BSNL are aware of the consequences of the Clause relating to the Penalty, the clauses relating to (a) forfeiture of security deposit (b) rescinding of the contract and have the balance of tendered work executed by another agency at the risk and cost of the defaulting contractor have to be read together as one single whole and interpreted with reference to each other and their provisions.

13.2 Penalty for causing inconvenience to the Public :

13.2.1 To ensure progress during the execution of work and to cause minimum inconvenience to the public, the contract shall not dig a trench of more than 200 meters at a stretch in a route at a time. He shall cause to lay cable and close such trenches expeditiously. Under any circumstances a stretch of trench of maximum 200 meters shall not be kept open for more than 4 days in case of cable laying by digging paved surfaces. In the event of contract falling to comply with, these conditions a penalty of recovery up to Rs. 300/- per day the trench is kept open beyond the item limit allowed may be imposed by the BSNL. This penalty will be in addition to that payable for delay or slow work.

13.2.2 The contractor shall not be allowed to dump the empty cable drums/waste materials in Govt./Public place, which may cause inconvenience to Govt./Public. If the contractor does not dispose off the empty cable drums/waste materials within 3 days of becoming empty, the BSNL is at liberty to dispose off the drum in any manner deemed fit and also recover the amount fixed in this contract for empty cable drums/waste materials from the bill/security deposit/along with the costs incurred by the BSNL in disposing off such materials. The BSNL may also levy a penalty up to Rs one thousand for each such default.

13.2.3 If any such penalty is levied on a contractor for more than 2 occasions, then his/her contract could be terminated. In this regard the decision of the GENERAL MANAGER TelecomBilaspur shall be final and binding.

13.3 Penalty for cutting /damaging the old cable:

13.3.1 During excavation of trench utmost care is to be taken by the contractor so that the existing underground cables are not damaged or cut. In case any damage/cut is done to the existing cables, a penalty as per the schedules given below will be charged from the contractor or the amount will be deducted from his running bills;

Size of existing UG/OF cables cut/damaged	Amount of penalty per cut/damage
Up to 100 pairs cable	Rs. 500.00 (Five Hundred)
About 100 pairs & up to 400 pairs	Rs. 1000.00 (One Thousand)
Above 400 pairs	Rs. 2000.00 (Two thousand)
Of Cable of any size	Rs. 5000.00 (Five Thousand)

OFC MTC. MARWAHI-PENDRA DISTRICT

Besides the above penalty, the contractor shall carry out such repairs for restoration of the damaged cable free of charge. The cost of jointing kit shall also be borne by the contractor. If contractor fails to repair the damage, the cost of repair (including cost of labour + Jointing kit) shall be recovered from the contractor.

- 13.3.2 Contractor shall either pay to third parties all expenditure incurred for restoring services which are damaged by Contractor while carrying out the work or the same amount will be deducted from his bills. Such expenditure shall be intimated to Contractor either by Engineer-in-charge or concerned third parties in writing. The amount deducted from the Contractor from his bill shall be paid to concerned third parties by Divisional Engineer or Accounts Officer.
- 13.3.3 Engineer-in-charge at his absolute discretion shall reserve the right to reject any bill submitted by the Contractor prior to making payment by him to third parties for the damages caused or to deduct same amount from his bill.
- 13.4 **Penalty to damage stores/materials supplied by the BSNL while laying**
- 13.4.1 The contractor while taking delivery of materials supplied by the BSNL at the designated place shall thoroughly inspect all items before taking them over. In case of execution of the work, if any material is found damaged / working unsatisfactorily, then a penalty equivalent to the cost of material + 10% as penalty shall be recovered from the contractor's payments securities.
- 13.4.2. In case of damage to O F cables, while laying, the cost of number of pairs damaged (including laying charges, transportation/storage charges) adding 10% as penalty shall be recovered from the contractor's bills/securities.
- 13.4.3. However, contractor will not be penalized for any defect in workmanship of the materials, which shall be taken up separately with the supplier of the stores.

14. Rescission/Termination of contract

- 14.1 **Circumstances for rescission of contract** : Under the following conditions of the contract :
- a. If the contractor commits breach of any item of terms and conditions of the contract.
 - b. If the contractor suspends or abandons the execution of work and the engineer in-charge of the work comes to conclusion that work could not be completed by due date for completion or the contractor had already failed to complete the work by that date.
 - c. If the contractor had been given by the officer-in-charge of work a notice in writing to rectify/replace any defective work and he/she fails to comply with the requirement within the specified period.
- 14.2 Upon rescission of the contract, the security deposit of the contractor shall be liable to be forfeited and shall be absolutely at the disposal of the BSNL as under :
- 14.2.1 Measurement of works executed since the date of last measurement and up to the date of rescission of contract shall be taken in the presence of the contractor or his authorized representative who shall sign the same in the MB. If the contractor or his authorized representative do not turn up for joint measurement, the measurement shall be taken by the officer authorized for this purpose after expiry of due date given for joint measurement. The measurement taken by the officer so authorized shall be final and no further request for joint measurement shall be entertained.
- 14.2.2 The unused material (Supplied by the BSNL) available at site, shall be transported back by the BSNL to the Telecom Store at the risk and cost of the contractor. If any such material is found damaged/lost then the penalty shall also be recovered from the contractor as per conditions in tender documents, *ibid*.

- 14.2.3 The un-executed work shall be got executed through the qualified bidder from amongst the bidders, who participated in the bidding process, by giving them offers in their order of ranking (L2, L3---) at their quoted rates . If the work was on single tender basis then the BSNL shall get the unexecuted work completed through any other contractor approved in the GMTD Bilaspur at the approved rates of the contractor. In such a event **no** compensation shall be payable by the BSNL to the contractor towards any inconvenience/loss that he may be subjected to as a result or such an action by the BSNL. In this regard the decision of (the SSA Head shall be final and binding. In all these cases, expenses which may be incurred in excess of the sum which would have been paid to the original contractor if the whole work had been executed by him shall be borne and paid by the original contractor and shall be deducted from any money due to him by the BSNL under the contract or any other account whatsoever any where in the BSNL or from a security deposit.
- 14.2.4 The certificate of the Divisional Engineer in-charge of work as to the value of work done shall be final and conclusive against the contractor, provided always that action shall only be taken after giving notice in writing to the contractor.

14.3 Termination for Insolvency:

The BSNL may at any time terminate the contract by giving written notice to the Contractor, without compensation to contractor, if the Contractor becomes bankrupt or otherwise insolvent as declared by the competent court provided that such termination will not prejudice or affect any right or action or remedy which has accrued or will accrue thereafter to the BSNL .

14.4 Optional Termination by BSNL (Other than due default of the contractor)

- 14.4.1 The BSNL may, at any time, at its option cancel and terminate this contract by written notice to the contractor, in which event the contractor shall be entitled to payment for the work done up to the time of such cancellation and a reasonable compensation in accordance with the contract prices for any additional expenses already incurred for balance work exclusive of purchases and/or whole of material, machinery and other equipment for use in or in respect of the work.
- 14.4.2 In the event of the termination of the contract, the contractor shall forthwith clear the site of all the contractor's materials, Machinery and equipment's and hand over possession of the work/operation concerned to the BSNL or as the BSNL may direct.
- 14.4.3 The BSNL may, at its option, cancel or omit the execution of one or more items of work under this contract and may part of such items without any compensation whatsoever to the contractor.

14.5 Issuance of Notice:

- 14.5.1 The Divisional Engineer in-charge of work shall issue show cause notice giving details of lapses, violation of terms and conditions of the contract, wrongful details or suspension of work or slow progress to the contractor directing the contractor to take corrective action a definite time schedule for corrective action shall be mentioned in the show cause notice. If the contractor fails to take corrective action within the stipulated time frame, the Divisional Engineer in-charge shall submit a draft of final notice along with a detailed report to the competent authority who had accepted the contract.
- 14.5.2 The final notice for rescission of contract to the contractor shall expressly state the precise date and time from which the rescission would become effective. The following safe guards shall be taken while issuing the final notice:
- a. During the period of service of notice and its effectiveness, the contractor should not be allowed to remove from the site any material/equipment belonging to the BSNL.

- b. The contractor shall give in writing the tools and plants he would like to take away/remove from the site. Such of the materials as belong to him and which may not be required for future execution of balance work may be allowed by the Divisional Engineer in-charge of work to be removed with proper records.
- c. No new construction beneficial to the contractor shall be allowed.
- d. Adequate BSNL security arrangement in replacement of the contractor watch and ward shall be made forthwith. Expenses on this account are recoverable form the security deposit or any amount due to the contractor.

15. INDEMNITIES:

- 15.1 The contractor shall at all times hold the BSNL harmless and indemnify from against all action, suits, proceedings, works, cost damages, changes claims and demands of every nature and descriptions, brought or procured against the BSNL its officers and employees and forthwith upon demand and without protect or demur to pay to the BSNL any and all losses and damages and cost (inclusive between attorney and client) and all costs incurred in endorsing this or any other indemnity or security which the BSNL may now or at any time have relative to the work or the contractors obligation or in protecting or endorsing its right in any suit on other legal proceeding, charges and expense and liabilities resulting from or incidental or in connection with injury, damages of the contractor or damage to property resulting from or arising out of or in any way connected with or incidental to the operations caused by the contract documents . In addition the contractor shall reimburse the BSNL or pay to the BSNL forthwith on demand without protect or demur all cost, charges and expenses and losses and damages otherwise incurred by it in consequences of any claim, damages and actions which may be brought against the BSNL arising out of or incidental to or in connection with the operation covered by the contractor.
- 15.2 The contractor shall at his own cost at the BSNL's request defend any suit or other proceeding asserting a claim covered by this indemnity, but shall not settle, compound or compromise any suit or other finding without first consulting the BSNL.

16. FORCE MAJEURE:

- 16.1 If any time, during the continuance of this contract, the performance in whole or in part by either party or any obligation under this contract shall be prevented or delayed be reason of any war, or hostility, acts of the public enemy, civil commotion sabotage, fires, floods explosions, epidemics, quarantine restrictions, strikes, lockouts or act of God (Herein after referred to as events) provided notice of happenings, of any such eventuality is given by either party to the other within 21 days from the date of occurrence thereof, neither party shall be reason of such event be entitled to terminate this contract nor shall either party have any such claim for damages against the other in respect of such non-performance and work under the contract shall be resumed as soon as practicable after such event may come to an end or cease to exist, and the decision of the BSNL as to whether the work have been so resumed or not shall be final and conclusive, provided further that if the performance in whole or part of any obligation under this contract is prevent or delayed by reason of any such event for a period exceeding 60 days either party may, at his obtain terminate the contract.
- 16.2 Provided also that if the contract is terminated under this clause, the BSNL shall be at liberty to take over from the contractor at a price to be fixed by the BSNL which shall be final, all unused, undamaged and acceptable materials, bought out components and stores in the course of execution of the contract, in possession of the contractor at the time of such termination of such portions thereof as the BSNL may deem fit excepting such materials bought out components and stores as the contracts may with the concurrence of the BSNL elect to retain.

17. ARBITRATION:

- 17.1 In the event of any question, dispute or difference arising under this agreement or in connection there with except as to matter the decision of which is specifically provided under this agreement, the same shall be referred to sole arbitration of the Chief General Manager, Chhattisgarh Circle or in case his designation is changed or his office is abolished then in such case to the sole arbitration of the officer for the time being entrusted whether in addition to the functions of the Chief General Manager Chhattisgarh Circle) or by whatever designation such officers may be called (hereinafter referred to as the said officer) and if the Chief General Manager, (Chhattisgarh Circle) or the said officer is unable or unwilling to act as such to the sole arbitration or some other person appointed by the Chief General Manager, or the said officer. The agreement to appoint an arbitrator will be in accordance with the Arbitration and Conciliation Act, 1996. There will be no objection to any such appointment that the arbitrator is BSNL servant or that he has to deal with the matter to which the agreement relates or that in the course of his duties as BSNL Servant he has expressed views on all or any of the matter under dispute. The award of the arbitrator shall be final and binding on the parties. In the event of such arbitrator to whom the matter is originally referred, being transferred or vacating his office or being unable to act for any reasons whatsoever such Chief GENERAL MANAGER or the said officer shall appoint another person to act as arbitrator in accordance with terms of the agreement and the person so appointed shall be entitled to proceed from the stage at which it was left out by his predecessors.
- 17.2 The arbitrator may from time to time with the consent of parties enlarge the time for making and publishing the award, Subject to aforesaid Indian Arbitration and Condition Act. 1996 and the Rules made there under, any modification thereof for the time being in force shall be deemed to apply to the arbitration proceeding under this clause.
- 17.3 The venue of the arbitration proceeding shall be the Office of the Chief General Manager, (Chhattisgarh Circle) or such other Places as the arbitrator may decide. The Following procedure shall be followed:
- 17.3.1 In case parties are unable to reach a settlement by themselves, the dispute should be submitted or arbitration in accordance with contract agreement.
- 17.3.2 There should not be a joint submission with the contractor to the sole Arbitrator.
- 17.3.3 Each party should submit its own claim severally and may oppose the claim put forward by the other party.
- 17.3.4 The onus of establishing his claims will be left to the contractor.
- 17.3.5 Once a claim has been included in the submission by the contractor, a reiteration or modification thereof will be opposed.
- 17.3.6 The "points of defense" will be based on actual conditions of the contract.
- 17.3.7 Claims in the nature of ex-gratia payments shall not be entertained by the Arbitrator as these are not contractual.
- 17.3.8 The question whether these conditions are equitable shall not receive any consideration in the preparation of "points of defense"
- 17.3.9 If the contractor includes such claims in his submission, the fact that they are not contractual will be prominently placed before the Arbitrator.
The award of the sole Arbitrator shall be final and binding on all the parties to the dispute.

18 **SET OFF:**

- 18.1 Any sum of money due and payable to the contractor (including security deposit refundable to him) under this contract may be appropriated by the BSNL or the Govt. or any other person or persons contracting through the Govt. of India/BSNL and set off the same against any claim of the BSNL or Govt. or such other person or persons for payment of a sum of money arising out of this contract made by the contractor with BSNL or Govt. or such other person or persons contracting through BSNL.

19. **COURT JURISDICTION**

“This tender is subject to Jurisdiction of Court at Bilaspur only”.

20. **Compliance of Provisions of EPF Act 1952**

The bidder must comply with the Provisions of EPF & Misc. Provisions Act, 1952 and employees Provident fund Scheme 1952, in respect of labourers/employees engaged by the bidder for carrying out works. The claim bill of contractor must accompany.

- (i) The list showing the details of labourers/ employees engaged.
- (ii) Duration of their engagement.
- (iii) The amount of wages paid to such labours/ employees for the duration in question.
- (iv) Amount of EPF contributions (both employer's & employees contribution), paid to the EPF Authorities.
- (v) Copies of Authenticated documents paid to EPF Authorities.
- (vi) A declaration from the bidder regarding compliance of the conditions of EPF Act 1952 must be submitted along with the bid.

Non compliance of above provision will be treated as breach of contract and necessary action against the bidder will be taken.

21. **GST Registration**

The contractor has to submit the registration of the GST. Otherwise no bill will be initiated for payment till the submission of GST registration.

SECTION VI

SPECIAL CONDITIONS OF CONTRACT

1. GENERAL

- 1.1 The work shall be accepted only after Testing carried out by the BSNL, as per prescribed schedule and work/material passing the test successfully.
- 1.2 The BSNL reserves the right to disqualify such bidders who have a record of not meeting contractual obligations against earlier contracts entered into with the BSNL
- 1.3 The BSNL reserves the right to black list a bidder for a suitable period in case he fails to honor his bid without sufficient grounds.
- 1.4 The BSNL reserves the right to counter offer price against price quoted by L-1 bidder.
- 1.5 Any clarification issued by BSNL/, in response to query raised by prospective bidders shall form an integral part of bid documents and it may amount to amendment of relevant clauses of the bid documents.
- 1.6 Tender will be evaluated as single package of all the items given in the price schedule.**
- 1.7 All work to be executed under the contract shall be executed under the direction and subject to the approval in all respects of by the Divisional Engineer or Site Engineer in-charge of work site who shall be entitled to direct at what point or points and what manner they are to be commenced, and from the time to time carried on.
- 1.8 The BSNL reserves the right to distribute the work to the other bidder on the approved rate seeing the quantum of work and on the basis of requirement and necessity.
- 1.9. If the contractor shall desire an extension of time for completion of the work on the grounds of unavoidable hindrance in execution of work or on any other ground he shall apply in writing to the Divisional Engineer within 3 days of the date of hindrance on account of which he desires such extension as aforesaid. In this regard decision of the GMTD, BSNL Bilaspur) shall be final.
- 1.10 If at any time after the commencement of the work, the BSNL may feel that execution of whole or part of work, as specified in the tender is not required to be carried out, then the BSNL shall give notice in writing of the fact to the contractor who shall have no claim to any payment of compensation whatsoever on account of any profit or advantage which he might have derived in consequence of the full amount of the work not having been carried out neither shall he have any claim for compensations by reason of any alterations having been made in the original specifications, drawings, design and instruction which shall involve any curtailment of the work as originally contemplated.
- 1.11 Whenever any claims against the contractor for the payment of a sum of money arises out of or under the contract, the BSNL shall be entitled to recover such sum by appropriating in part or whole the security deposit of the contractor, and to sell any BSNL promissory notes etc. forming the whole or part of such security or running / Final bill pending against any contract with the BSNL. In the event of the security being insufficient or if no security has been taken from the contractor, then the balance or the total sum recoverable as the case may be, shall be deducted from any sum then due or which at any time there after may become due to the contractor under this or any other contract with BSNL . Should this sum be not sufficient to cover the full amount recoverable the contract or shall pay to BSNL on demand the balance remaining due.

- 1.12 No official of Gazetted rank or other Gazetted officer employed in Engineering or administrative duties in BSNL/DOT/MTNL is allowed to work as a contractor for a period of two years after his retirement from BSNL service without the previous permission of BSNL of India. This contract is liable to be cancelled if either the contractor or any of his employee is found at any time to be such a person who hadn't obtained the permission of BSNL of India as aforesaid before submission of the engagement in the contractor's service as the case may be.
- 1.13 In the event of the contractor being, adjusted insolvent or going voluntarily into liquidation of having received order or other order under insolvency act made against him or in the case of company, of the passing of any resolution, or making of any order for winding up whether voluntarily or otherwise, or in the event of the contractor failing to comply with any of the condition herein specified, The (the SSA Head/ Director(Projects)) shall have the power to terminate the contract without any notice .
- 1.14 Without prejudice to any of the rights or remedies under this contract, if the contractor dies, the GMTD Bilaspur on behalf of the President can terminate the contract without compensation to the contractor. However the GMTD Bilaspur, at his discretion may permit contractor's heirs to perform the duties or engagements of the contractor under the contract, in case of his death. In this regard the decision of the GMTD Bilaspur shall be the final.
- 1.15 In the event of the contractor, winding up his company on account of transfer or merger of his company with any other, the contractor shall make it one of the terms and stipulations of the contract for the transfer of his properties and business, that such other person or company, shall continue to perform the duties or engagement of the contractor under this contract and be subject to his liabilities there under.

1.16 Interpretation of the contract document

- 1.16.1 The representative of the GMTD Bilaspur and the contractor shall in so far as possible by mutual consultation, try to decide upon the meaning and intent of the contract document. In case of disagreement the matter shall be referred to (the SSA Head/Director(Project)) whose decision shall be final. Any change in the contract documents shall be set forth in writing by the representative of the parties hereto. It shall be the contractor's responsibility to thoroughly familiarize all of his supervisory personnel with the contents of all the contract documents.

1.2 Notification

- 1.2.1 The contractor shall give in writing to the proper person or authority person or authority with a copy to the Divisional Engineer such notification as may be mandatory or necessary in connection with the commencement, suspension, resumption, performance and/or completion of the contracted work. All notice shall be given sufficiently in advance of the proposed operation to permit proper co-relation of activities and the contractor shall keep all proper persons or authorities involved and advised of the progress of operations throughout the performance of the work and/or with such other information and/or supporting figure and data as may from time to time as directed or required.

1.3 Shut down on account of weather conditions:

- 1.3.1 The contractor shall not be entitled to any compensation whatsoever by reason of suspension of the whole or any part of the work made necessary by the BSNL or deemed advisable on account of bad weather conditions or other Force major conditions.

2. STORES SUPPLIED BY THE BSNL :

- 2.1 The BSNL will provide sufficient impress stock of PLB pipe, OF cable & joint closures. This stock will be replenished on monthly basis for the consumed quantities.

OFC MTC. MARWAHI-PENDRA DISTRICT

- 2.2 In case BSNL is not in position to supply PLB, OFC & joint closures, it will be the responsibility of the vendor to arrange these items to the extent of 10% of estimated quantity of tender. The material arranged shall be of the same standard as supplied by BSNL & shall be used after the clearance of BSNLs officer in-charge of the work.
- 2.3 At no point of time the contractor shall be issued stores of value more than the contractor's material security as per clause number 5(i) of **SECTION-V**. If at all the work requires more amount of materials to be issued, the contractor will not have any objection to it.
- 2.4 The contractor shall transport (including loading and unloading) all stores issued to him from District Telecom Store, to the site of work at his own cost. The BSNL shall not pay any transportation charges to the contractor.
- 2.5 All materials supplied to the contractor by the BSNL shall remain the absolute property of BSNL and shall not be removed from site of the work except for use in the work and shall be at all times open to inspection by the Representative of GMTDBilaspur. In case the materials like cable and accessories are taken delivery of by the contractor and stored at the site office/store will also be treated "as site" for this purpose. Any such materials remaining unused at the time of the abandonment, completion or determination of the contract shall be returned to the BSNL at a place informed to him by the BSNL, failing which the cost of the unused materials shall be deducted from the contractor's material security or any of his pending bills or from any other security.
- 2.6 The contractor shall be responsible for the transportation of store, storage and safe custody of all material supplied to him by the BSNL, which in the contractor's custody whether, or not installed in the work. The contractor shall satisfy himself regularly the quantity and quality of the materials supplied to him and he will be responsible for any subsequent deterioration and discrepancy (inclusive of theft) in the quantity/quality of the materials.
- 2.7 The contractor shall submit a proper account every months of all the materials supplied to him by the BSNL and those consumed for items of work any discrepancy of difference between the materials issued to the contractor and those consumed in the work as per the "BSNL's calculation" (which shall be final) will be charged to the contractor or deducted from his bills at 1.5 times of prevailing standard price including freight, handling charges, storage, charges etc.
- 2.8 The contractor shall ensure that only the required materials are issued to him. Upon completion of work, the contractor shall return to the Govt. at the later designated store in good condition, free of charges, any unused materials that were supplied by the BSNL
- 2.9 The contractor shall supply all items which are not specifically mentioned to be supplied by BSNL.

3. EASEMENTS, PERMITS, LICENCES AND OTHER FACILITIES:

- 3.1 The contractor shall obtain/provide at his own cost all easements, permits and license necessary to do its work except for the following which shall be provided by the Representative of the (the SSA Head/Direction (Projects)):
- A. "Right of User" easements and permits.
 - B. Railway and Highway crossing permits including bridge.
Canal/stream crossing permits.
- 3.2 The contractor shall be fully responsible for angling and obtaining all necessary easements, permits and licenses, for moving all construction equipment, tools, supplied materials and men across Railways and Highway, across public or private road as well as premises of any public utility within the right of user and for bearing all costs that may be incurred in respect of the same.

- 3.3 The contractor is to confine his operation to the provided construction "Right of User" unless it has made other arrangement with the particular property owners and /or tenants such other arrangements shall be entirely at the responsibility of the contractor as to cost and arrangement as also breach and claim and shall be entitled with a copy to the Divisional Engineer.
- 3.4 The contractor will not be entitled to extra compensation for hardship and increase in cost by the cable trench being routed adjacent to or across other pipeline, Highways, Railways, telephones or pole poles and wires or guy wires, embankments, cliffs, streams or other obstacles which may physically or otherwise in any manner, restrict or limit the use of the construction "Right of User". Some construction and such contingency shall be deemed to have been providing for in the rates.
- 3.5 At location where the OF cable trench is routed across or along railways or roads the contractor shall without extra cost provide and maintain such detours and road controls as are required by the railways or BSNL or local agencies having jurisdiction.
- 3.6 If the BSNL is not able to provide above mentioned permits etc. in time then the extension of time limit shall be provided as per EOT clause given in tender document.

4. QUALITY OF WORK:

- 4.1 The BSNL/ shall be the final judge of the quality of the work and the satisfaction of the BSNL/ in respect thereof set forth in the contract documents. Laxity or failure to enforce compliance with the contract documents by the BSNL and/or its representative shall not manifest a change or intent of waiver, the intention being that , notwithstanding the same, the contractor shall be and remain responsible for complete and proper compliance with the contract documents and the specification there in . The representative of GMTD Bilaspur/ has the right to prohibit the use of men and any tools, materials and equipment which in his opinion do not produce work or performance meet the requirement of the contract documents.

5. TAXES AND DUTIES:

- 5.1 Contractor shall pay all rates, levies, fees royalties, taxes and duties payable or arising from out of, by virtue of or in connection with and/or incidental to the contract or any of the obligations of the parties in terms of the contractor documents and/or in respect of the works or operations or any part thereof to be performed by the contractor and the contractor shall indemnify and keep indemnified the BSNL from and against the some or any default by the contractor in the payment thereof.

6. PROTECTION OF LIFE AND PROPERTY AND EXISTING FACILITIES:

- 6.1 The contractor is fully responsible for taking all possible safety precaution during preparation for and actual performance of the works and for keeping the construction site in a reasonable safe condition. The contractor shall protect all life and property from damage or losses resulting from his construction operations and shall minimize the disturbance and inconvenience to the public.
- 6.2 If the excavation of trench alters the contours of the ground road and highway crossing in such locations dangerous to traffic, the contractor shall at his own cost, take all necessary precautions to protect public and shall comply with all the BSNL regulations as to placing of warning boards (Minimum size 3'x2'), traffic signals barricades, flags etc., at such location. If the contractor does not put the warning signal as per above direction, then a penalty of Rs. 500/- per day shall be levied on the contractor, till the directions are complied by the contractor. The contractor shall take due precautions to avoid damages to other pipe lines, water mains, sewers, telephones, telegraphs and power conduits, laid wires poles and guy wires, railways, highways, bridges or

OFC MTC. MARWAHI-PENDRA DISTRICT

other underground or above ground structure and/or property crossing or adjacent to the cable trench being excavated.

- 6.3 Attention of the contractor is drawn to the rules regarding laying of cables at road crossing, along Railways Bridges, Highways safety precautions while working in Public Street. The contractor in writing shall obtain the detailed engineering instructions from the Divisional Engineer of the area.
- 6.4 The contractor shall be solely responsible for location through approved non destructive means and ensuring the safety of all existing underground pipeline, electrical cables, and or other structures.
- 6.5 The contractor shall be solely liable for all expense for and in respect of repairs and / or damage occasioned by injury of or damage to such underground and above structures or other properties and under take to indemnify the BSNL from and against all actions, cause of actions, damages, claims and demands what so ever, either in law or in equity and all losses and damages and costs (inclusive between attorney and client) charges and expenses in connection therewith and/or incidental thereto. The contractor shall take all responsibilities and risk in crossing other pipelines and cables and shall be responsible for protecting all such existing pipelines, poles, electric lines, sewers cable or other facilities from damage by the contractor's operation in connection with the work. The contractor without cost of the BSNL shall promptly repair any damage incurred.
- 6.6 The current market value of any commodities lost as a result of any damage to the aforesaid existing facilities shall be paid by the contractor together with such additional sums necessary to liquidate the personal of property damages, resulting there form.

7. LABOUR WELFARE MEASURES AND WORKMAN COMPENSATION:

7.1 Obtaining License before commencement of work:

The contractor shall obtain a valid labour license under the contract Labour (R&A) Act 1970 and the Contract Labour (Regulation and Abolition) Central Rules 1971, before commencement of the work and continue to have a valid license until the completion of the work. The contractor shall also abide by the provisions of the Child Labour (Prohibition and Regulation) Act 1986. Any failure to fulfill this requirement shall attract the penal provisions of this contract arising out of the resultant non execution of work.

7.2 Contractors Labour Regulations:

7.2.1 Working Hours

7.2.1.1 Normally working hours of an employee should not exceed 9 hours a day. The working day shall be so arranged that inclusive of interval for rest, if any, it shall not spread over more than 12 hours on any day.

7.2.1.2 When a worker is made to work for more than 9 hours on any day or for more than 48 hours in any week he shall be paid over time for the extra hours put in by him.

7.2.1.3 Every worker shall be given a weekly holiday normally on a Sunday, in accordance with the provisions of Minimum Wages (Central) Rules 1960, as amended from time to time, irrespective of whether such worker is governed by the minimum Wages Act or not.

7.2.1.4 Where the minimum wages prescribed by the BSNL, under the Minimum Wages act, are not inclusive of the wages for the weekly day of rest, the worker shall be entitled to rest day wages, at

the rate applicable to the next preceding day, provided he has worked under the same contractor for a continuous period of not less than 6 days.

7.2.1.5 Where a contractor is permitted by the Engineer-in-charge to allow a worker to work on normal weekly holiday, he shall grant a substituted holiday to him for the whole day, on one of the five days, immediately before or after the normal weekly holiday, and pay wages to such worker for the work performed on the normal weekly holiday at the overtime rate.

7.2.2 **Display of Notice Regarding Wages Etc.**

The contractor shall, before he commences his work on contract, display and correctly maintain and continue to display and correctly maintain, in a clear and legible condition in conspicuous places on the work, notices in English and in local Indian languages spoken by the majority of the workers, giving the minimum rates of the wages fixed under Minimum Wages Act, the actual wages being paid, the hours of work for which such wage are earned, wages periods, dates of payments of wages and other relevant information .

7.2.3 **Payment of Wages**

7.2.3.1 The contractor shall fix wage periods in respect of which wages shall be payable.

7.2.3.2 No wage period shall exceed one month.

7.2.3.3 The wages of every person employed as contract labour in an establishment or by a contractor, where less than one thousand such persons are employed, shall be paid before the expiry of seventh day and in other cases before the expiry of tenth day after the last day of the wage period in respect of which the wages are payable.

7.2.3.4 Where the employment of any worker is terminated by or on behalf of the contractor, the wages earned by him shall be paid before the expiry of the second working day from the date on which his employment is terminated.

7.2.3.5 All payment of wages shall be made on a working day at the work premises and during the working time and on a date notified in advance and in case the work is completed before the expiry of the wage period, final payment shall be made within 48 hours of the last working day.

7.2.3.6 Wages due to every worker shall be paid to him direct or to other person authorized by him in this behalf.

7.2.3.7 All wages shall be paid in current coin or currency or in both.

7.2.3.8 All wages shall be paid without any deductions of any kind except those specified by the Central BSNL by general or special order in this behalf or permissible under the Payment of Wages Act 1956.

7.2.3.9 A notice showing the wages period and the place and time of disbursement of wages shall be displayed at the place of work and a disbursement of wages shall be displayed at the place of work and a copy sent by the contractor to the Engineer-in-Charge under acknowledgement.

7.2.3.10 It shall be the duty of the contractor to ensure the disbursement of wages in presence of the site Engineer or any other authorized representative of the Engineer-in-Charge who will be required to be present at the place and time of the disbursement of wages by the contractor to workmen.

7.2.3.11 The contractor shall obtain from the site Engineer or any other authorized representative of the Engineer-in-Charge, as the case may be, a certificate under his signature at the end of the entries in the "Register of Wages" or the "Wage-cum-Muster Roll", as the case may be, in the following form:-

"Certified that the amount shown in the column No..... has been paid to the workman concerned in my presence on at" "

7.2.4 Fines and deductions which may be made from wages

7.2.4.1 The wages of a worker shall be paid to him without any deduction of any kind except the following;

a. Fines

- b. Deductions for absence from duty i.e. from the place or the places where by the terms of his employment he is required to work .The amount of deduction shall be in proportion to the period for which he was absent.
- c. Deductions for damage to or loss of goods expressly entrusted to the employed person for custody, or for loss of money or any other deductions which he is required to account, where such damage or loss is directly attributable to his neglect or default.
- d. Deduction for recovery of advances or for adjustment of overpayment of wages, advances granted shall be entered in a register.
- e. Any other deduction which the central BSNL may from time to time, allow

7.2.4.2 No fines should be imposed on any worker save in respect of such acts and omissions on his part as have been approved of by the Labour Commissioner.

7.2.4.3 No fine shall be imposed on a worker and no deduction for damages or loss shall be made from his wages until the worker has been given an opportunity of showing cause against such fines or deductions.

7.2.4.4 Every fine shall be deemed to have been imposed on the day of the act or omission in respect of which is imposed.

7.2.5 Labour records

7.2.5.1 The contractor shall maintain a muster roll register in respect of all workmen employed on work on contract in Form XIII of the Contract Labour (R&A) Central Rules 1971.

7.2.5.2 The contractor shall maintain a Muster Roll register in respect of all workmen employed by him on the work under Contract in Form XVI of the CL (R&A) Rules 1971

7.2.5.3 The contractor shall maintain a Wage Register in respect of all workmen employed by him on the work under contract in Form XVII of the CL (R&A) Rules 1971.

7.2.5.4 **Register of accidents** - The contractor shall maintain a register of accidents in such form as may be convenient at the work place but the same shall include the following particulars.

- a. Full Particulars of the labourers who met with accident.
- b. Rate of wages
- c. Sex
- d. Age
- e. Nature of accident and cause of accident
- f. Time and date of accident

OFC MTC. MARWAHI-PENDRA DISTRICT

- g. Date and time when admitted in hospital
- h. Date of discharge from the hospital
- i. Period of treatment and result of treatment
- j. Percentage of loss of earning capacity and disability as assessed by Medical Officer.
- k. Claim required to be paid under Workmen's compensation Act.
- l. Date of payment of compensation.
- m. Amount paid with details of the person to whom the same was paid.
- n. Authority by whom the compensation was assessed.
- o. Remarks

7.2.5.5 The contractor shall maintain a Register of Fines in the Form XII of the CL (R&A) Rules 1971
The contractor shall display in a good condition and in a conspicuous place of work the approved list of acts and omission for which fines can be imposed.

7.2.5.6 The contractor shall maintain a Register of deductions for damage or loss in Form XX of the CL(R&A) Rules 1971.

7.2.5.7 The contractor shall maintain a Register of Advances in form XXIII of the CL (R&A) Rules 1971.

7.2.5.8 The contractor shall maintain a Register of Overtime in Form XXIII of the CL(R&A) Rules 1971.

7.2.6 Attendance card-cum wage slip

7.2.6.1 The contractor shall issue an Attendance card cum wage slip to each workman employed by him.

7.2.6.2 The card shall be valid for each wage period.

7.2.6.3 The contractor shall mark the attendance of each workman on the card twice each day, once at the commencement of the day and again after the rest interval, before he actually starts work.

7.2.6.4 The card shall remain in possession of the worker during the wage period under reference.

7.2.6.5 The contractor shall complete the wage slip portion on the reverse of the card at least a day prior to the disbursement of wages in respect of the wage period under reference.

7.2.6.6 The contractor shall obtain the signature or thumb impression of the worker on the wage slip at the time of disbursement of wages and retain the card with him.

7.2.7 Employment card

The contract shall issue an Employment Card in the Form XIV of CL (R&A) Central Rules 1971 to each worker within three days of the employment of the worker.

7.2.8 Service certificate

On termination of employment for any reason whatsoever the contractor shall issue to the workman whose services have been terminated, a service certificate in the form XV of the CL(R&A) Central Rules 1971.

7.2.9 Preservation of labour records

The labour records and records of Fines and deductions shall be preserved in original for a period of three years from the date of last entries made in them and shall be made available for

inspection by the Engineer-in-charge or labour officer or any other officers authorised by the Ministry of communication in this behalf.

7.3 Power of labour officer to make investigations or enquiry

The labour officer or any person authorized by the central BSNL on their behalf shall have power to make enquires with a view to ascertaining and enforcing due and proper observance of fair wage clauses and provisions of these Regulations . He shall investigate into any complaint regarding the default made by the contractor in regard to such provision.

7.4 Report of Investigating officer and action thereon

The labour officer or other persons authorized as aforesaid shall submit a report of result of his investigation or enquiry to the Engineer in-charge indicating the extent, if any, to which the default has been committed with a note that necessary deductions from the contractor's bill be made and the wages and other dues be paid to the labourers concerned. The engineer incharge shall arrange payments to the labour concerned with 45 days from the receipt of the report from the labour officer or the authorized officer as the case may be.

7.5 Inspection of Books and Slips

The contractor shall allow inspection of all the prescribed labour records to any of his workers or to his agent at a convenient time and place after due notice is received or to the labour officer or any other person, authorized by the central BSNL on his behalf.

7.6 Submission of Returns

The contractor shall submit periodical returns as may be specified from time to time.

7.7 Amendments

The central BSNL may from time to time add to or amend the regulations and on any question as to the application/interpretation or effect of those regulations.

8.0 INSURANCE:

Without limiting any of his other obligations or liabilities the contractor shall, at his own expense, take and keep comprehensive insurance including third party risk for the plant, machinery, men, materials etc. brought to the site and for all the work during the execution. The contractor shall also take out workmen's compensations insurance as required by law and under take to indemnify and keep indemnified the BSNL from and against all manner of claims and demands and losses and damages and cost (including between attorney and client) charges and expenses that may arise in regard the same or that the BSNL may suffer or incur with respect to end/or incidental to the same. The contractor shall have to furnish originals and/or attested copies as required by the BSNL of the policies of insurance taken with 15 (fifteen) days of being called upon to do so together with all premium receipts and other papers related thereto which the BSNL may require.

9. COMPLIANCE WITH LAWS AND REGULATIONS

During the performance of the works the contractor shall at his own cost and initiative fully comply with all applicable laws of the land and with any and all applicable by laws rules, regulations and orders and any other provisions having therefore of law made or promulgated or deemed to be made or promulgated by the BSNL, BSNL agency or BSNL, municipal board, BSNL of other regulatory or Authorized body or persons and shall provide all certificates of compliance therewith as may be required by such applicable law. By-laws, Rules, Regulations, order and / or provisions. The contractor shall assume full responsibility for the payment of all contributions and pay roll taxes as to its employees, servants or agents engaged in the

performance of the work specified in the contractor documents. If the contractor shall require any assignee or subcontractor to sham any portion of the work to be performed hereunder may be assigned, subleased or sub contracted to comply with the provisions of the clause and in this connection the contractor agrees as to undertake to save and hold the BSNL harmless and indemnified from and against any/all penalties, actions, suits, losses and damages, claims and demands and costs (inclusive between attorney and client charges and expenses whatsoever arising out or occasioned, indirectly or directly, by failure of the contractor or any assignee or sub-contractor to make full and proper compliance with the said by laws, rules regulation law and order provision as aforesaid.

10. TOOLS and PLANTS

The contractor shall provide at **his own cost all tools, plants appliances, implements, measuring instruments , digging instruments like excavators / backhoe loader** etc. required for proper execution of works. The contractor shall also supply without charge the requisite number of persons with the means and materials necessary for the purpose of setting out works, counting, weighing and assisting the measurements for examination at any time and from time to time. The contractor shall be responsible to make all arrangements, at his own cost for dewatering of trenches/ducts and de-gasification of the ducts before carrying out work. The contractor shall also be responsible to make arrangements, at his own cost for water required for carrying of works at sites including curing of CC/RCC works. Failing his so doing the same may be provided by the Engineer-in-charge at the expense of the contractor and the expenses shall be deducted form any money due to the contractor under this contract or otherwise.

11. **Compliance of Provisions of EPF Act 1952**

The contractor will ensure compliance of Employees Provident Fund & Misc. Provisions Act 1952 & Employees Provident Fund Scheme 1952 in respect of laborers/ employees engaged by him for performing the works of BSNL.

12. The permission for laying cables will have to be arranged by the contractor from National High Way Authorities, State PWD, and Local bodies (Like Municipal Corporation, Nagar Palika, Panchayats etc.) and from any other authorities, if required.
13. **In view of OFC routes of BSNL have been laid for more than 5 – 10 years . the RIDs fails to show the correct location and offsets in present times due to road , Culverts and drainage and widening of roads in almost all locations. In the regard , contractor must locate the cable as early as possible and restore it in timely manner.**

SECTION VII

SCOPE OF WORK AND JURISDICTION OF CONTRACT

1. SCOPE OF WORK

Scope of work of the contract includes

Primary

1.1.Maintenance of OFC network according to time schedule.

Secondary

1.2.Time bound permanent restoration of fault in case fault is restored on temporary basis.

2. THE CONTRACTORS OFFICE

2.1 The Contractor's office to be situated centrally in allotted work area.

Following facilities are to be provided by the Contractor on priority basis within 7 days from the issue of LOI:

- i. Telephone / or Mobile.
- ii. E-mail facility with PC (Laptop/Desktop).
- iii. Furniture.
- iv. Store room &Storage Cupboards/Racks.
- v. Emergency repairs tool kit.

2.2 Each FRT shall be located strategically situated so as to reach the fault location promptly.

3. DETAILS OF THE MAPOWER / SERVICES TO BE PROVIDED BY THE CONTRACTOR.

The Contractor shall deploy regular manpower for the following works:

- a. Preventive and Corrective Maintenance
- b. Supervision
- c. Sufficient FRTs with manpower for all types of splicing and corrective activities.FRT should normally consist of
 - Splicer :01,
 - Asstt Splicer :01
 - Labourers : 02
 - Vehicle :01
- d. Labor and machine – for corrective maintenance / Aerial cabling
- e. Labor and Machine for permanent maintenance of fault.

3.1 General conditions.

- 3.1.1 **Route length shall be the physical road length/trench length and not OFC cable length**
- 3.1.2 **The Contractor shall not deploy any staff member, who is found unsuitable by BSNL.**
- 3.1.3 BSNL also shall give the Names, Designations, Mobile/landline, and FAX Nos., office /residential addresses of BSNL staff responsible for each stretch to the Contractor before commencement of this contract.

- 3.1.4 If the FRT observes that work is being carried out around the BSNL node or route by any other Contractor/Agency/Individuals not mentioned above. He must take charge of the situation, take Preventive action immediately and inform the BSNL representative. **During any network threatening activity on route and during and after the course of preventive maintenance the contractor must arrange for the site to be guarded by a guard or unskilled labor specially kept for this purpose till the time the network is made underground or the threat to network averted as per BSNL need.**
- 3.1.5 Contractor has to keep good relationship and co-ordination with the entire Local govt & Non govt. bodies/ agencies, farmers, private construction etc to collect their plans, which may impact the BSNL network.
- 3.1.6 **Any Preventive Maintenance/Corrective activity, involving extra billing by the Contractor should be pre-authorized by BSNL in writing; else no payment shall be made.**

3.2 Fault reporting / restoration mechanism:

On occurrence of fault BSNL will communicate to contractor through e-mail or sms. However, agency has to ensure hourly taken from dashboard with SSA Nodal officer. Proper recording of fault reporting / restoration between BSNL and vendor needs to be maintained. The contractor shall acknowledge the receipt of fault report by return mail. To ensure proper billing in absence of any automated system the information should be shared through emails for record purpose. **Fault restoration report along with time of restoration should be sent by contractor to BSNL. BSNL will verify & then acknowledge it by mail.**

3.3 PREVENTIVE AND CORRECTIVE MAINTENANCE:

- 3.3.1 Corrective activity would involve taking all corrective actions in restoration of any OFC fault in the network.
- 3.3.2 After reporting of fault contractors team should localize fault using OTDR and fault restoration team (FRT) should reach the spot promptly.

The optical Fibre cable is laid through PLB pipes buried at a nominal depth of 165 cms. For localization of fault / restoration of fault, normally trenching along already existing route will be reqd. Immediate restoration of fault may be followed by permanent restoration of temporarily restored faults wherever reqd. work will be executed under supervision of site In-charge. If any change in route is reqd for permanent restoration of fault, same will be brought to notice of BSNL officers and will be implemented with due permission of BSNL. Length of rerouted work will decide works to be treated as mtncnc or capital nature. For works to be capitalized standard procedure of A/T shall be followed.

- i. Excavation of trench upto existing route depth a nominal depth of 165 cms., according to construction specifications.
- ii. Laying of PLB pipes / coils coupled by PLB sockets in excavated trenches, on bridges **and** culverts, drawing of 4 mm Polypropylene rope (P.P. rope) through the PLB pipes/coils as per construction specifications and sealing of PLB pipe ends at every manhole by PLB and caps of suitable size.
- iii. Providing of mechanical protection by R.C.C. Pipes/GI pipes and/or concreting/chambering according to construction specifications, wherever required.
- iv. Fixing of GI. Pipes / troughs with clamps at culverts/bridges and / or chambering or concreting of G.I. Pipes/troughs, wherever necessary.
- v. Back filing and dressing of the excavated trenches to original state.
- vi. As per requirement , Opening of manholes (of size 3 meters x 1 meter x 1.65 meters depth), replacing existing 4 mm P.P. ropes by 8 mm P.P. rope (from manhole to manhole) for ensuring smooth passage for pulling the cable. Pulling of Optical Fibre Cable with proper tools and accessories as per construction specifications. Sealing of both ends of the manholes by hard rubber bush of suitable size to avoid entry of rodents into the PLB pipes, putting split PLB pipes and split RCC pipes with proper fixtures over cable in the manhole to protect the bare cable in the pulling manhole. Back filling and dressing of manholes.

OFC MTC. MARWAHI-PENDRA DISTRICT

- vii. Digging of pit of size 2 meter x 2 meter x 1.8 meter (depth) for construction of jointing chamber as per the requirement of internal size of 1.5 meter x 1.5 meter x 1.2 meter **using** bricks and mortar or fixing pre-cast jointing chamber of internal diameter of 1.2 meter filling of jointing chamber with clean sand, placing either pre-cast RCC cover or stone of suitable size on jointing chamber to protect the joint and back filling of jointing chamber with excavated soil.
- viii. Splicing of fibers in existing /New Joint chambers for making Straight or branch joints. End to end testing of all fibers after splicing.
- ix. Installation and splicing of splitters at the splice locations or any other location.
- x. Splicing of all the fibers of 24F OFC cable in the fiber termination box and testing of all fibers for continuity whenever required.
- xi. Digging of pits 1 meter towards jungle side at every manhole and jointing chamber to a depth of 60 cms. Fixing of route Indicator/joint indicator, concreting and back filling of pits. Painting of route indicators with **Blue** colour and joint indicator by **Grey** colour and sign writing denoting route/joint indicator number, as per construction specification.
- xii. **Documentation.**-Preparation / updating and supply of route index diagrams hard as well as soft copy in CD for the repair routes.
- xiii. In case of conflict between scope of work and jurisdiction of contract in section VII and Engineering instruction in section VIII, the Engineering instruction shall prevail.

- 3.3.3 Resources to be deployed by the Contractor: The Contractor shall deploy sufficient manpower & Equipments under this work contract.
- 3.3.4 For preventive maintenance as and when a network threatening activity is observed by the patroller he shall use all possible means to avert the loss to network, however if due to any circumstances the damage to physical network in a particular stretch can not be avoided, the contractor shall ensure that preventive action (aerial cabling) is done in time so that when the actual damage happens the network downtime is avoided or is minimum that is equal to the splicing time involved at the two ends of the aerial cable.
- 3.3.5 After the immediate temporary restoration plan should be submitted for permanent restoration by the contractor to the head and after subsequent approval work is to be completed within agreed timeline.
- 3.3.6 The contractor would be responsible for carrying out the necessary actions for the permanent restoration / network relocation as per the agreed rate and the activity should be completed within agreed timeline. The contractor shall keep adequate resources to take-up the activity and to ensure its completion in time.
- 3.3.7 The scope of activity under permanent restoration/network relocation shall include, trenching, ducting, fiber pulling, splicing etc.
- 3.3.8 Patch cord / pig tail /connector / attenuator fault at OLT and GP end are to be attended by vendors & no separate charges will be paid for attending such faults.
- 3.3.9 Supervisor: The contractor shall depute a supervisor for the awarded work who shall coordinate the preventive and corrective maintenance activities and also the activities of all the resources i.e FRTs deployed by contractor and shall be the single point of contact of BSNL. He shall keep in daily liaison with BSNL's O&M Engineer.

3.4

3.5 RESPONSE AND RESTORATION TIME WHEN IT IS A CORRECTIVE MAINTENANCE:

- 3.5.1 The Time To Restore (TTR) will be different for BSNL OFC & incremental OFC of NOFN.
- 3.5.2 **Time to restore (TTR) for BSNL OFC will be : 8 Hours**
- 3.5.3 **N/A . Any fault reported on incremental OFC will be restored by 8 PM next day.**
- 3.5.4 **Period between 8 PM to 8 AM will be exempted while counting the fault duration (TTR).**

- 3.4.5 Penalty of Rs. 200/- for delay of each hour will be levied if fault is not restored within TTR.
- 3.4.6 If the fault is restored on temporary basis its permanent restoration should be carried out within 48 hours
- 3.4.7 If the permanent restoration work is not carried out within 48 hours, without any specific reason, penalty of Rs. 500/- per day will be levied.
- 3.4.8 Maximum penalty will be 10% of the cost of contract.
- 3.4.9 Response time is the time taken by the Contractor to mobilize (set in Motion) all the necessary resources (like materials, labor and equipments) required for executing the preventive or Corrective Maintenance. The Agency should promptly mobilize the resources on reporting of fault by BSNL.
- 3.4.10 As a potential threat is reported by the patroller, suitable preventive actions should be taken so as to prevent and loss to network or live traffic in OF cable.
- 3.4.11 Temporary restoration through aerial cabling and Mechanical Splice of active Fibers should not exceed 8 hrs. from the time BSNL conveys that a cable fault has occurred. This time frame includes identifying the location of the fault; mobilize the resources and up to the time the traffic is restored...
- 3.4.12 In case of undue delay in fault restoration BSNL is at liberty to get it restored by other means & the cost incurred will be reimbursed by the contractor.

4. CONTRACTOR TO ACQUAINT HIMSELF AS TO THE CONDITIONS OF THE WORK / SUPPLY

- 4.1 The Contractor shall make allowance for all contingencies in the contract price. The Contractor shall not raise any claims or objections against BSNL in any matters, which include but not limited to the nature of work, site conditions, right of way, surface and water conditions, local conditions and all other related issues.
- 4.2 The acceptance and execution of the contract shall be considered as evidence that such an examination was made and later claims for labor, equipment or materials required for difficulties encountered shall not be allowed.
- 4.3 The prices quoted by the contractor are and shall be considered to be based on his own knowledge and judgment of the conditions and hazards involved.
- 4.4 The Contractor shall be deemed always to have satisfied himself as to the correctness and sufficiency of the tender and of the rates and prices stated in the scheduled of quantities all of which shall except in so far as it is otherwise provided in the Contract, cover all his obligations under the Contract.

5. MATERIALS

- 5.1 Issue of material by BSNL: All the essential critical materials as listed below will be issued by BSNL for stocking with the contractor. PLB pipe / OFC / SJC / Splitter will be supplied by BSNL. Stores like patch cords, pig tails, connectors, attenuators & also material required for joint chambers, concreting, joint indicators etc. The storage and transportation cost from the BSNL Bilaspur stores to the contractor warehouse is to be borne by the contractor. Also the ownership of the material issued to contractor from BSNL warehouse lies wholly with contractor.
- 5.2 BSNL will provide sufficient imprest stock of PLB pipe, OFC, Joint closures & splitters. **This stock will be replenished on monthly basis for consumed quantities. in case BSNL is not in position to supply PLB, OFC, joint closures & splitters, it will be the responsibility of the vendor to arrange these items to the extent of 10% of estimated quantity of tender.** The material arranged shall be of the same standard as supplied by BSNL & shall be used after the clearance of BSNL officer-in-charge of the work. Agency will be paid for these items as per BSNL approved rates.

OFC MTC. MARWAHI-PENDRA DISTRICT

- 5.3 Depending on the field conditions the contractor shall keep adequate spares / material in his warehouse and the unavailability of material at the time of any fault shall be considered as a lapse on the part of contractor.
- 5.4 The contractor has to provide monthly material usage report to Branch Head and each usage of material has to be certified by BSNL O&M engineer and BSNL Team Leader.
It shall be the responsibility of contractor to maintain adequate stock of store items at its location and replenish before depletion. For this purpose Contractor shall send requirements by the 1st Day of the Month, in the prescribed format. Usually BSNL will make the material available at its premises mentioned elsewhere, within one week of receiving the requirements from the Contractor.
- 5.5 In case of theft/loss/damage to materials while in the custody of the Contractor, BSNL shall assess and recover an amount equivalent to the loss incurred by BSNL. This recovery shall be made against payments to Contractor against various bills and various Bank Guarantees submitted by the contractor for various purposes.
- 5.6 This action taken by BSNL shall not be limited to above but may be to the extent of cancellation of contract and or Black Listing of the contractor.
- 5.7 It shall be the Contractor's responsibility to safeguard all materials as above against theft, loss damage or whatsoever. It shall be the responsibility of contractor to maintain adequate stock of above at its locations and replenish before depletion under advice to BSNL O&M Engineer.
- 5.8 For the materials listed under this Clause, Contractor shall maintain a record register on replenishment and consumption, with date and countersigned by BSNL O&M Engineer on each incidence of consumption (cable cut time)/replenishment.

6 MATERIALS AND EQUIPMENTS TO BE SUPPLIED / PROVIDED BY THE CONTRACTOR

- 6.1 The contractor shall provide all the material required for fault restoration except the items supplied by the BSNL. The contractor shall provide petty items like patch cords, pig tails, connectors etc. The tools and test and measurement equipment provided by the contractor shall be inspected by O&M Engineer BSNL. If the quality of the tools or the technical standard of any test and measurement instrument is found below average and declared so by the BSNL representative the contractor shall replace the instrument / tool with immediate effect.
- 6.2 The tools and test and measurement instrument of any FRT shall not be moved to any other sites/ works without written permission of O&M Engineer -BSNL.
- 6.3 Contractor shall at all times maintain a Vehicle for each Fault Repair Team..
- 6.4 The FRT vehicle should be in excellent working condition and should be replaced in case of any malfunctioning/damage/declared unfit by BSNL representative.

7 DISPATCH

- 7.1 The goods, if any, to be supplied by the Contractor shall be dispatched and delivered well in time to suit the MTTR period specified in the contract.
- 7.2 Failure to meet the stipulated MTTR periods for inadequate supply of goods, or for any other reasons, shall be subject to the provisions of Penalties under this agreement.

8 SUB-CONTRACTS

The Contractor shall not sub-contract any part or the whole of the work, without the prior written consent of BSNL.

9 REJECTION

Further BSNL shall also be entitled to reject the goods and work executed by the contractor which may not be conforming to specifications, within a reasonable time after installation or first use of the said goods and materials or service, if testing or inspections subsequently prove these to be non-conforming and charge the contractor for all the expenses, direct and consequential incurred thereby.

10 SECRECY CLAUSE

10.1 BSNL will issue as built drawings to the Contractor for their reference and to understand the route. Contractor has to inform & update the as built as and when any rectification is done in the particular route. The technical information, drawings, specifications and other related documents forming part of the tender or the contract are the property of the BSNL. All rights including rights based on prior user, copyrights and rights in the event of grant of a patent and registration of designs are reserved exclusively by BSNL.

10.2 In the event of any breach of this provision, the Contractor shall indemnify BSNL from any loss, cost or damage or any other claim whatsoever from BSNL's collaborators and/or any other parties claiming from or through them or from any other party in respect of such breach.

11 BSNL INSTRUCTION

BSNL may, in its absolute discretion, from time to time, issue further drawings and /or instructions, details, directions, modifications, Variations, specifications and explanations etc; which are collectively referred to as BSNL's INSTRUCTIONS.

12 CONTRACTOR'S OBLIGATIONS

The Contractor shall proceed with execution of the contract in the best and most expeditious manner by engaging qualified, careful and efficient workers and complete the work strictly in conformity with the plans, drawings, schedules and BSNL instructions.

13 SUPPLY OF TOOLS,EQUIPMENT AND OTHER MATERIAL

The Contractor shall not dispose of, transport or withdraw any tools, tackles, equipment and material provided by him for the contract without taking prior written approval from DE/AGM OFC incharge BSNL, who at all times shall have right to refuse such permission, if in BSNL opinion, the same will adversely affect the safety/efficiency of the work.

14 EXECUTION OF WORK

14.1 The contractor at all times shall work in co-ordination with BSNL's Representative/supervisory staff who will offer them all reasonable facilities to become familiar with the operation and maintenance activities.

14.2 In respect of observations of local rules and regulations, administrative orders, working hours the contractor and his personnel shall fully cooperate with BSNL and follow BSNL instructions. The Contractor shall be responsible for compliance with all statutory requirements including personnel related matters.

14.3 The Contractor shall not sell, assign, mortgage, hypothecate or remove Equipment or materials which have been installed or which may be necessary for the completion of the contract, without the prior written consent of DE/AGM OFC incharge BSNL.

14.4 The Contractor shall strictly comply with safety regulations indicated elsewhere in this agreement for strict compliance.

14.5 The Contractor shall, throughout the execution and completion of the works and the remedying of any defects therein, take all reasonable steps to protect the Environment on and off the site and to avoid damage or nuisance to persons or to property of the public or others resulting from

pollution, noise or other Causes arising as a consequence of his methods of operation and shall be exclusively liable and responsible for the same.

15 TEST AND INSPECTION

- 15.1 The Contractor shall provide for the purpose of inspection, ladders, lighting, Equipment for testing, necessary instruments etc., at his own cost.
- 15.2 All results of inspection and test will be recorded in the inspection reports, Performa of which shall be approved by DE/AGM OFC incharge BSNL. These reports shall form part of the completion documents for payments.

16 EXAMINATION OF WORK BEFORE COVERING UP WHILE PERMANENT RESTORATION OF FAULT

The Contractor shall give advance notice to BSNL or its representatives whenever any work or materials are intended to be covered up in the earth, in bodies or walls or otherwise to be placed beyond the reach of measurement, in order that the work may be inspected or that correct dimension may be taken before being so covered, placed beyond reach of measurement. In default of such notice, the same shall, at the option of BSNL or its representative, be uncovered and measured at the Contractor's expenses. The work shall again be covered up at the Contractor's expenses.

17 EXAMINATION OF FINISHED WORK

- 17.1 When finished work is taken down for the purpose of inspection, the Contractor shall bear the entire expenses incidental thereto in the event that the said work is found to be defective. BSNL shall pay the cost incidental thereto in the event there is no default of notice and if it is also in accordance with the specifications.
- 17.2 After executing the corrective maintenance the Contractor shall submit to the BSNL's O&M engineer the revised RID/ABD (as-built drawings) in both soft and hard copy.

18 PROTECTION OF EXISTING PLANT AND EQUIPMENT

- 18.1 During construction activity by another Contractor / Agency, any plant, equipment or heavy machinery in the vicinity of BSNL network, the Contractor shall protect all existing structures, piping conduits, equipment and facilities of BSNL against damage.
- 18.2 BSNL shall not be responsible or held liable for any damage to person or property consequently upon the use, misuse or failure of any construction tools and equipment of BSNL used by the contractor or any of his sub-contractors, even though such construction tools and equipment may be furnished, rented or loaned to the contractor or any of his sub-contractors. The Contractor accepts all responsibility in this connection and agrees to indemnify and save harmless BSNL from any and all claims for said damages arising out of or resulting from said use/misuse or failure of such construction tools and equipment.
- 18.3 Adequate lighting at and near all the storage, handling, erection sites, OSP site for properly carrying out work and for safety and security shall be provided and maintained by the Contractor. If the Contractor fails to provide all the above listed facilities, BSNL may provide such facilities as it may deem necessary and charge the cost thereof to the contractor. In any case, the contractor shall be liable for all damages and consequences arising out of his neglect in this regard.

19 CLEARING / CLEAN UP OF SITE

- 19.1 All soil, filth or other matter taken out of any trench, sewer, drain, cesspool or other place shall not be deposited on the surface, but shall at once be carted away by the contractor from the site of work, for suitable and proper disposal as directed by BSNL.
- 19.2 The contractor shall be responsible for the safe and secure storage of any material or equipment.

20 REVIEW MEETING

The contractor shall attend all the review / site meetings as required by BSNL. The venue and the timings of such meetings shall be decided by BSNL. The meeting for perforce review should take place in the first week of every month and the rating should be submitted to HQ in format attached in ANNEXURE C.

21 STATUARY APPROVALS

- 21.1 It shall be the contractor's responsibility to furnish all particulars and furnish necessary application forms to the concerned authorities on behalf of BSNL, if so required, and satisfy all requirements and obtain approval. This shall also include obtaining ROW Permissions from respective Authorities for maintaining/relocating of cable trenches/ Handholes /other network resources if so be required.
- 21.2 BSNL shall provide any assistance possible and shall reimburse the Contractor for payments made to various government agencies upon submittal of the required permits and official receipts.

22 NIGHT WORK AND WORK IN MONSOON

- 22.1 The Contractor may be expected to work during night time hence contractor required to keep sufficient labor in his camp on 24X7 basis to carry out emergency civil maintenance work at any time.
- 22.2 Sufficient lighting arrangement shall be provided by the Contractor to safeguard the workmen and the public and to afford adequate facilities for properly placing and inspecting the materials and work when the night work is in progress.
- 22.3 Where night work is in progress, all excavated areas shall be barricaded, guarded and shall be provided with red lights at the cost of contractor and all other work area shall be well illuminated to prevent accidental falls etc.
- 22.4 The Contractor shall carryout Patrolling the entire stretch on monsoon seasons also. The Contractor shall maintain an adequate labor force and appropriate equipment, as may be required for the project and plan and execute the work according to the prescribed schedule. No extra payment will be considered for such work in monsoon.
- 22.5 The contractor shall make necessary arrangement to ensure that the maintenance activity both preventive and corrective are carried out as per plan and need and within timelines as agreed in the contract even during the monsoon. This may include providing for power and resources with rain suits, shoes, tent and proper lighting.

23 CONTRACT PRICE

- 23.1 Contract price shall include all traveling expenses to and from the site, allowances, living expenses, wages, salaries, overtime, benefits and all compensations.
- 23.2 It shall also include insurance carried by the Contractor for his workers, workmen's compensation, tools and tackles, plants and aids, third party liability and any other insurance as called for in General & Special conditions of this contract.
- 23.3 The price shall also include cost of all licenses and permits, cost of procurement, loading, transport and unloading of all his material, tools and tackles instruments and construction aids to and from the site, cost of providing office and accessories, tool room, Quarters, canteen

workshops and all facilities at site as may be required, cost of supply of all material required under the contract, applicable taxes and duties, performance of all services as required under the contract and satisfactorily executing the complete work under the contract.

23.4 If any fees are to be paid to the statutory authorities for testing, inspection or calibration, these shall be considered by the contractor and included in his pricing and if not so done, the same shall be the contractor's responsibility.

23.5 GST/ Work Contract tax shall be paid as applicable.

24 INCOME TAX ON CONTRACTOR'S STAFF / EMPLOYEES

The Contractor's staff, personnel and labor will be liable to pay personal income taxes in respect of such of their salaries, wages and allowances, if any as are required by Govt. Authorities.

25 LIQUIDATED DAMAGES / PENALTY CLAUSE

25.1 If the contractor not restored the fault within TTR, a penalty of Rs. 200 per hr, subject to maximum 10% of restoration cost of that fault will be imposed.

25.2 If the permanent restoration work is not carried out within 48 hours, without any specific reason, penalty of Rs. 500/- per day will be levied.

25.3 Maximum penalty will be 10% of the cost of contract.

25.4 If the splice losses in the fibers spliced in a cable during any fault on an average should be limited to 0.05 dB. If loss exceeds norm, the contractor would be required to make good at his own cost again.. In case BSNL mobilizes resource to reduce the dB loss in the spliced fibers, then BSNL shall deduct Rs.7,000/- per incident. Consistent performance below average in respect of above notified in writing to the contractor would result in termination of contract at discretion of BSNL.

25.5 BSNL shall have absolute right at its sole discretion to en-cash any /all bank guarantee/s provided by the contractor to BSNL, under this or any other contract/s in the event:

- i) As per LOI issued by BSNL, Contractor has not rectified to the satisfaction of BSNL within the time specified by BSNL and or
- ii) The contractor fails to rectify any/all damages during the course of work even after directions from BSNL to do so and or
- iii) The contractor fails to perform his obligations under this contract and or
- iv) BSNL is put to loss, damage, what so ever under the situation contemplated in clause 34.1.

26 TERMINATION OF CONTRACT BY BSNL

26.1 BSNL shall be entitled to interrupt and terminate the contract at any time should, in BSNL's opinion, the cessation of work become necessary, owing to paucity of funds of the contractor, the contractor's apparent inability to perform, consistent poor performance notified in writing, or from any other cause whatsoever. In such case, the value of approved materials utilized at site and of certified and accepted work done to date by the contractor shall be paid for in full at the rates specified in the contract subject to the clause of liquidated damages contemplated herein. All such materials become the property of the BSNL.

26.2 The amounts held in the "hold back" account shall be released, within a reasonable time after making the adjustments if any, payable by the contractor. Notice in writing from the BSNL of such termination and the reason thereof shall be conclusive evidence of taking over of works from the contractor.

26.3 The contractor shall have no claim for any payment or compensation or otherwise howsoever on account of any anticipated profits or advantages which he did not derive from the execution of the work in full.

27 WITHDRAWAL OF THE CONTRACTOR FROM THE CONTRACT

- 27.1 Save under the circumstances as stated in Clause 27.4, in case, the Contractor wishes to withdraw from the Contract on their own, the Contractor shall inform head, i.e. in writing regarding the same with proper justification / reasons supporting their withdrawal from the Project.
- 27.2 However, the Contractor shall give a minimum notice period of Ninety Calendar Days to **BSNL** in this regard.
- 27.3 BSNL shall review the Contractor's representation in this regard and would decide on the future course of action within one month of the notice by the Contractor. In case, no communication is made by BSNL to the Contractor in this regard within One Month of receipt of notice from the Contractor, it shall be deemed to have the Approval of BSNL..
- 27.4 In case, BSNL gives a written permission to the Contractor for withdrawal from the Project, the following activities have to be completed by the Contractor within one month's time from the date of receipt of permission from BSNL:
- i. The Contractor shall return the Authorization letters given to them by BSNL.
 - ii. The Contractor shall return the valid and Pending Demand Drafts that were issued by BSNL for Payment of Monthly Electricity, Telephone, Rents etc. (if any) and submit a statement of total payments done by them at respective locations.
 - iii. The Contractor shall also reconcile and surrender the materials issued by BSNL in a safe and secure place indicated by BSNL at no extra cost to BSNL.
 - iv. The Material Reconciliation Statement shall be duly endorsed by BSNL Team Leader. The original copy of the same shall be attached to the Final Bill by the Contractor and submitted to BSNL.
 - v. .In case, the Contractor does not hand over the Surplus Material issued by BSNL for O&M maintenance, BSNL shall back charge the Contractor an Amount equal to Landed Cost of Materials.

28 COMMUNICATIONS TO BE IN WRITING

All notices, communications, references and complaints made by the BSNL or his representative or the contractor inter se concerning the works shall be in writing. Notices, communications, references or complaints not in writing shall not be recognized.

29 COMPLIANCE WITH STATUARY LAWS / REGULATIONS

- 29.1 The contractor warrants that all goods/systems supplied and work done under the contract shall conform to all applicable city, State and central laws, ordinances and all relevant statutory regulations. Further, the contractor shall indemnify, keep indemnified and defend and save BSNL harmless from loss, cost or damage by reason of any actual or alleged violation thereof.
- 29.2 The contractor shall ensure compliance with all relevant statutes, laws, rules and regulations of the Central or State Government or any other authority such as the Workmen's Compensation Act, payment of wages Act, Minimum wages Act, Employees State Insurance Act, Employees provident Fund Act, Apprentices Act, Contract Labour Regulations & Abolition Act, etc., and any/all other applicable statutes and all modifications thereof, in connection with labour/ employees engaged by him or his sub-contractors in the work. The **Contractor** shall furnish **BSNL** all necessary documents, challans etc. in respect of payments towards Provident Fund / Employees State Insurance and under other statues on periodical basis as required by BSNL.
- 29.3 The contractor shall conform to the provisions of Indian Boiler Regulation, Indian Factory Rules, Indian Electricity Act and any other acts of legislature relating to the work and to the regulations and bylaws of any authority and of any water, lighting and other companies and/ or authorities with whose systems the project is proposed to be connected and shall, before making any variations from the drawings or specifications that may be necessitated, give to **BSNL**

written notice, specifying the variations proposed to be made and the reason for making it and apply for instructions thereon.

- 29.4 The **Contractor** shall indemnify **BSNL** in respect of all actions, suits, claims and deeds brought or made against BSNL by the workmen of the **Contractor** in the execution of or in connection with the work, notwithstanding that all reasonable and proper precautions may have been taken by **Contractor**. He shall also indemnify against any loss or damage to BSNL in consequence of any action or suits or proceedings (civil and /or criminal) being brought against BSNL for anything done or omitted to be done in connection with the execution of work. The indemnity given by **Contractor** as aforesaid shall extend to making good all claims and deeds proceedings (civil and /or criminal) arising out of the losses /damages to property of every description and kind, the infringement of any legal right, as well as injury or accident to any person resulting in death or otherwise.
- 29.5 Contractor agrees to and does hereby accept full and exclusive liability for compliance with all obligations imposed by the Employees State Insurance Act, 1948 and contractor further agrees to defend, indemnify and hold Central, State or Local Authority by reason of any asserted violation by and also from all claims, suits or proceeding that may be brought against BSNL arising under, growing out or by reasons of work provide (for by this contract whether brought by Central or State Government authority or any political sub-division thereof).
- 29.6 Contractor agrees to fill in with the Employees' State Insurance Corporation, the declaration form, and all forms which may be required in respect of contractors or sub-contractor's employees, and who are employed in work provided for under contract as required under the said act, contractor shall deduct and secure the agreement of the sub-contractors to deduct the employees contribution as per the first schedule of the Employees' State Insurance Act form wages and affix the Employee's contribution cards at wages payment intervals. Contractor shall remit and secure the agreement of sub-contractor to remit to the State Bank of India, Employee's State Insurance Corporation Account, the Employees contribution's required by the Act.
- 29.7 Contractor agrees to maintain all cards and records as required under the Act in respect of employees and payments and contractor shall secure the agreement of the Sub-contractor to maintain such records. Any expenses incurred for the contribution, making contributions or maintaining records shall be to contractors or sub-contractors account.
- 29.8 BSNL shall retain such sum as may be necessary from the contract price until contractor, shall furnish satisfactory proof that all contributions as required by Employees' State Insurance Act, 1948, have been paid.

30 STATUTES, REGULATIONS AND JURISDICTION

- 30.1 The Contractor shall indemnify BSNL and every member, officer, and employee of BSNL, as also the BSNL's Officer-In-Charge and Route-In-Charge against all actions, proceedings, claims, deeds, costs and expenses whatsoever arising out of or in connection with damage to property and all actions, proceedings, claims, deeds, costs and expenses which may be made against BSNL for or in respect of or arising out of any failure by the contractor in the performance of his obligations under the contract.
- 30.2 BSNL shall not be liable and cannot be held liable for or in respect of any deduction or compensation payable by law in respect of or in consequence of, any accident or injury to any workmen or other person in the employment of the contractor or his sub-contractor and the contractor shall indemnify and keep indemnified BSNL against all such damages and compensations and against all claims, damages, proceedings, costs charges and expenses whatsoever in respect thereof or in relation thereto.

31 PAYMENT OF CLAIMS AND DAMAGES

- 31.1 Should BSNL have to pay any money in respect of any claims or deeds whatsoever, as aforesaid, as described herein inclusive of the amount so paid and the costs

OFC MTC. MARWAHI-PENDRA DISTRICT

incurred by BSNL in respect of any damage or loss to any property belonging to third party or to any public utility service, shall be charged to and paid by the contractor and he shall not be at liberty to dispute or question the right of BSNL to make such payments on any ground whatsoever, notwithstanding the same may have been made without his consent or authority, or law, or otherwise to the contrary.

31.2 In every case in which by virtue of the provisions of section 12, sub-section (1) of workmen's Compensation Act, 1923 or other applicable provision of Workmen's Compensation Act or any other Act, BSNL is obliged to pay compensation to workmen employed by the contractor and/or his sub-contractors in execution of work, BSNL shall be entitled to recover from the contractor the amount of compensation so paid, and without prejudice to the rights of BSNL under section 12, sub-section (2) of the said Act.

31.3 BSNL shall be at liberty to recover such amount, or any part thereof, by deducting it from the Security Deposit of from any sum due to the contractor whether under this contract or otherwise. BSNL shall not be bound to contest any claim made under section 12, sub-section (1) of the said Act, except on written request of the contractor and upon his giving to BSNL full security for all costs for which BSNL might become liable in consequence of contesting such claim. BSNL shall have a lien on the amount due to the contractor in respect of any amount that may be claimed by BSNL and/or payable by the contractor under any of the provisions of the contract.

32 INSURANCE AND RISK

32.1 Contractor has to take third party Liability Insurance Policy at his own cost.

32.2 The policy shall be to cover third party (claims arising out of injury and/or property damage) for a limit of Rs.10 Lacs (per event/agreement limit i.e. 1:1) including cross liability.

33 ADDITIONAL CLAUSES

33.1 The policy shall contain a suitable clause whereby BSNL shall be named as 'co insured' under the policy.

33.2 The policy shall contain a suitable clause whereby BSNL shall be named as 'loss-payee' under the policy.

33.3 The insurance policies will be effective during the entire duration of the contract.

33.4 The Contractor shall ensure the satisfactory payment of premium and other charges payable under the above policies and shall be responsible for satisfactory and expeditious compliance of all procedures, formalities, and other terms and conditions relating to the policy and maintenance of the policy including any claims hereunder.

33.5 The contractor shall submit to BSNL a copy of the policies as well as receipts for the payment of premium and/or any other charges in respect of the above policies.

33.6 The contractor shall not cancel or terminate or curtail the insurance policies in any matter without the prior express approval of BSNL.

33.7 The Contractor shall take a Comprehensive All Risk Policy for the materials issued by BSNL from time to time from the date of issue till a period of 6 months on the name of BSNL. On submission of Original Documents of Insurance Premium paid BSNL shall reimburse the relevant charges.

NOTWITHSTANDING ANYTHING TO THE CONTRARY CONTAINED ABOVE: the following terms are agreed to in addition to those that are set out above:

34 INDEMNIFICATION

- 34.1 The Contractor hereby releases and shall indemnify, defend and hold harmless the BSNL and its subsidiaries and affiliates and their officers, agents, employees, successors and assignees and authorized representatives against any and all suits, actions, legal or administrative proceedings, claims, deed, damages, liabilities, interests, attorney's fees, costs and expenses of whatsoever kind or nature, including those arising out of damage to property (including but not limited to property of third parties, principal) and injury to or death of persons (including but not limited to the contractors, employees and third parties) whether arising during or after completion of the work hereunder and in any ner directly or indirectly caused, occasioned, or contributed to in or whole or in part, or claim to be caused, occasioned or contributed to in whole or in part, by reason of any act, omission, fault or negligence whether active or passive of the contractors, sub-contractors or of any one acting under its direction or control or on its behalf in connection with or incidental to the perforce of this contract.
- 34.2 The Contractor shall pay and meet all expenses including legal costs incurred by BSNL in responding to and defending all such claims and the contractor shall meet and pay all damages awarded against BSNL and keep BSNL harmless and indemnify to the fullest extent.
- 34.3 There will not be any claim against BSNL for any claim not recovered and/ or short recovered from the insurance company such amount shall be borne by the contractor himself.
- 34.4 In the event, BSNL is required to pay any royalty, penalty or other sum by whatever name known to any of its contracting partners or agencies, either on account of time over runs or the project not being made operational in full by the contractor, or suffering any other disability, loss, damage or other inconvenience, on account of any delays or lapses in executing the project and rendering it fully operational, for any reasons not attribute directly to BSNL, the contractor agrees and undertake to indemnify, keep indemnify and save harmless BSNL from all such costs, damages, expenses, disability in such ner that at the first instance.

35 WORKS AT RISK AND COST OF CONTRACTOR

In the event the contractor fails to execute the work as per agreed productivity/ quality norms of works as mentioned elsewhere in this contract and timelines, BSNL after giving one week notice to the executed/ re-executed through any other contractor /subcontractor / agencies as BSNL deems fit and proper at the costs and expenses of the contractor, provided however that if the estimated cost for execution of such work as certified by the BSNL's representative shall be less than the proportionate contract price the benefit, there from, shall be to BSNL's account. And if the same shall be estimated more than the proportionate contract price, the excess amount incurred by BSNL in this connection shall be reimbursed by the contractor, which may be adjusted by the BSNL against any outstanding dues payable to the contractor under this contract. BSNL shall have the right to retain and hold in its custody and possession of all requisite equipment, materials, tackles, machinery etc. belonging to the contractor in connection with the work, as it deems necessary so as to put them in use in the event to the contractor does not perform/ fails to fulfill his obligations as per this agreement, or his workshop is found to be substandard or not as per specifications of BSNL, at any point of time during the tenure of this agreement. BSNL shall be at liberty to sell the materials belonging to the contractor if in the opinion of BSNL, it is necessary to avoid any loss / hardship/ damages that may be incurred by BSNL on account of the contractors failure to execute the work to the satisfaction of BSNL.

36 STORAGE AT SITE

- 36.1 The contractor shall be fully responsible for storage of all materials covered in his scope. BSNL shall allow storage in its Stations wherever available on the NLD route. BSNL will issue the materials covered in its scope to the contractor at BSNLs warehouse points and it will be the sole responsibility of the contractor to transport such materials to his designated storage places or sites and safeguard the same against any theft, loss or damage whatsoever. Transportation cost incurred by the Contractor shall be reimbursed at actual.

- 36.2 Any tax implications including octroi etc. during the transport within the territory shall be the responsibility of the contractor. During the currency of the contract, the contractor shall be responsible for the safe custody of such materials delivered by BSNL till the final installation and will make good, any shortages/ damages which occur during transportation to the sites / storage at its cost. The contractor shall also furnish a weekly report of consumption of BSNL supplied materials to enable BSNL logistic to monitor the progress and arrange to supply additional quality of such materials covered in the scope of BSNL as and when required.
- 36.3 The Contractor may be required to work in monsoon seasons also. The Contractor shall mobilize the additional resources and appropriate equipment, as may be required for the project and plan and execute the works according to the prescribed schedule. No extra payment will be considered for such work in monsoon except if special vehicle is hired instead of a motorcycle with prior written consent of BSNL.

37 MATERIAL RECONCILIATION

- 37.1 It shall be the effort of the Contractors to reduce wastage at every level.
- 37.2 At the end of the specified work as per work order BSNL would undertake a joint reconciliation of all the materials issued. Maximum allowable wastage for various items are mentioned below:
- i. Pipes wastage not greater than 1%
 - ii. Cables wastage not greater than 1%
- However, the O&M Engineer shall assess the wastage of materials on a case to case basis and recommend a suitable course of action.
- 37.3 Any shortfall would be to the contractors account calculated on the basis of the cost incurred by the BSNL for procuring these items and would be deducted from the final bill.

38 MISCELLANEOUS

No party shall publish any press release or otherwise publicity disclose the existence of this contract or any of its Terms and Conditions, without the express prior written consent of the other party, following advance review by consenting party of the text of the press release or other public disclosure.

SECTION - VIII

Engineering instruction for Optical Fibre Cable Maintenance Specifications

The detailed Optical fiber construction specifications are given in document titled as "**Engineering instruction**" for Optical Fiber Cable maintenance under NOFN Project of through BSNL Manual" attach with tender documents. The bidders are advised to go through the manual before quoting for bid.

Signature of Bidder

Name of the Bidder
(Capacity in which signing)

Station:

Date

ENGINEERING INSTRUCTIONS ON UNDER GROUND OPTICAL FIBRE CABLE MAINTENANCES

1.0 SCOPE

1.1 The Engineering Instructions spelt out in this document deal with the methods to be adopted for underground Optical Fiber Cable laying in PLB HDPE ducts and inter connection of the existing Optical Fiber Cables with the newly laid OF cables and termination of OF Cables at Gram Panchayats (GPs) for National Optical Fiber Network.

2.0 INTRODUCTION

2.1 The existing core Optical Fiber Cable (OFC) network already deployed by various service providers mostly covers State/District/Area headquarter but does not extend upto most of the Gram Panchayats. Under the NOFN project all 250000 Gram Panchayats across the country are proposed to be connected to the Area HQs by laying incremental Optical Fiber Cable.

3.0 OF CABLE LAYING APPROACH

3.1 Restoration of Road surface:- On the basis of the survey reports routes for OF cable laying shall be finalized. Road Cutting Permission shall be obtained from road and rail authorities for laying the Optical Fiber Cable along the finalized roads and at rail / road crossing along the route. Generally O.F. Cable may preferably be laid straight as far as possible along the road near the boundaries, away from the burrow pits.

When the O.F. Cable is laid along the National Highways, Cable should run along the road land boundary or at a minimum distance of 15 meters from the center line of the road where the road land is wider as the OFC carries high capacity traffic and is planned for about 25 to 30 years of life.

It is essential that the cable is laid after obtaining due permission from all the concerned authorities to avoid any damage (which may result in disruption of services / revenue loss) and shifting in near future due to their planned road widening works.

3.1(a) RRSB: Road restoration work to be made with bituminous macadam for semi grouting 50 mm thick and premix carpet surfacing 25 mm thick over the grouted surface (total up to 75 mm thick) including supply of asphalt etc. to evenly match the road, including consolidation and rolling as per standard specification of DSR 1997.

3.1(b) RRSC: Road restoration work with cement concrete 1:4:8 mix for thickness varying from 150 mm to 225 mm, including supply of concrete to be made to evenly match the road.

3.2 In special cases where it may be necessary to avoid burrow pits or low lying areas, the Cable may be laid underneath the shoulders at a distance of 0.6 meter from the outer edge of the road embankment provided the same is located at least 4.5 meters away from centre line of road.

4.0 GENERAL

4.1 Soil Classification

Soil shall be classified under two broad categories Rocky and Non Rocky, The soil is categorized as rocky if the cable trench cannot be dug without blasting and / ofchiseling. All other types of soils shall be categorized as Non Rocky including Murrum& soil mixed with stone or soft rock.

1. Rocky soil.

The terrain which consists of hard rocks or boulders where blasting/ chiseling is required for trenching such as quartzite, granite, basalt in hilly areas and RCC (reinforcement to be cut through but not separated) and the like.

2. Non Rocky soils.

This will include all types of soil- soft soil/hard soil/murumie. any strata, such as sand, gravel, loam, clay, mud, black cotton murum, shingle, river or nullah bed boulders, soling of roads, paths etc. (All such soils shall be sub-classified as **kachcha soil**) and hard core, macadam surface of any description (water bound, grouted tarmac etc), CC roads and pavements, bituminous roads, bridges, culverts (All such soils shall be classified as **Pucca soils**)

4.2 The Optical Fibre Cable shall be laid through PLB HDPE Ducts buried at a nominal depth of 165 cms. The steps involved in OF Cable construction are as under

4.2.1. Excavation of trench upto a nominal depth of 165 cms. **in non-Rocky soil**, according to construction specifications. Along National/State Highways/other roads and in built up / rural areas. Under exceptional conditions/ genuine circumstances due to site constraints/ soil conditions, relaxation can be granted by the competent authority for excavation of trench to a depth lesser than 165cm. Such relaxation shall be given as per the laid down norms/ procedures being followed by the concerned CPSUs for their own works and with the approval of the competent authority. The payment in such cases shall be made on pro-rata basis as per the existing norms adopted by the concerned CPSUs.

4.2.2. Laying of PLB HDPE Ducts/coils coupled by sockets in excavated trenches, on bridges and culverts, as per construction specification and sealing of PLB HDPE Ducts pipe ends at every manhole by end-plugs of appropriate size.

4.2.3. Providing additional protection by R.C.C. Pipes/GI pipes and/or concreting/chambering, wherever required according to construction specification.

4.2.4. Fixing of GI pipes/troughs with clamps on culverts/bridges and/or chambering or concreting of G.I. Pipes/troughs, wherever necessary. Normally, RCC/DWC pipes shall be used and use of GI pipes shall be avoided. However, in case it is felt that GI pipe is unavoidable in certain circumstances this should be done with the prior approval of competent authority within the concerned CPSUs. This shall be recorded appropriately.

4.2.5. Laying Protection Pipes On Bridges And Culverts. In case trenching and pipe laying is not possible on the culverts, the pipes shall be laid on the surface of the culverts/bridges after due permission from the competent authority **as per construction specification**

4.2.6. Back filling and Dressing of the Trench according to construction specifications.

4.2.7. Making manhole (of size 2.0 m length x 1.0 m width x 1.65 m Depth) at every Cable pulling location for housing the OF Cable loop & Pulling Optical Fibre Cable using proper tools and accessories. Sealing of both ends of the PLB HDPE pipe in manhole by hard rubber bush of suitable size to avoid entry of rodents into the PLB DPE Ducts, putting split PLB HDPE Ducts and split RCC pipes with proper fixtures over cable in the manhole to protect the bare cable.

4.2.8. Digging of pit of size 2 meter x 2 meter x 1.8 meter (depth) for fixing of Jointing chamber precast RCC cover or stone of suitable size on Jointing chamber to protect the Joint and back filling of jointing chamber with excavated soil.

4.2.9. Digging of pits 500 cm to 1000 cm towards jungle side at every manhole and jointing chamber along the route to a depth of 75 cms., fixing of route Indicator/joint indicator, concreting and back filling of pits. Painting of route indicators with Blue colour and joint Indicator by Grey colour and sign writing denoting route/joint indicator number and marked as “”, as per construction specification.

4.3 Specifications of Materials to be used

4.3.1. PLB HDPE Duct

Optical Fiber Cables should be pulled through Permanently Lubricated HDPE Duct of 40 mm/33mm size conforming to the specifications as per TEC GR No. TEC/GR/TX/CDS-008/03/MAR-11 with latest Amendments. The Ducts shall be blue in colour and have the identification markings as per TEC GR wherein logo shall be marked as BSNL Ballarpur's name.

4.3.2. PLB HDPE Duct Accessories

a) Push fit Coupler

Push Fit couplers shall be used for coupling PLB HDPE ducts/coils. The specifications of the couplers shall be as per TEC GR no TEC/GR/TX/CDS-008/03/Mar11 with latest amendments.

b) PP Rope

Should confirm to TEC GR No. TEC/GR/TX/CDS-008/03/MAR-11 with latest Amendments.

However, this is optional and CPSUs may use the same on need basis. The PP rope can be ordered alongwith the PLB duct as required. In this case PP rope is drawn through the HDPE/PLB pipes/coils and safely tied to the end caps at either ends with hooks to facilitate pulling of the OF cables at a later stage. The rope used is 3 strands Polypropylene rope having yellow colour and size of **4 mm diameter for 40mm/33mm duct and conform to IS 5175 with minimum slackness of 2%** It should have a minimum breaking strength of 550 kgs. The length of each coil of rope should be 5 meter more than the standard length of duct (or as ordered) and it should conform to (i) BS 4928 Part-II of 1974 (ii) IS 5175 of 1982. It should be of special grade and should have ISI certificate mark. It should be manufactured out of industrial quality Polypropylene.

b) End Cap

End Cap shall be used for sealing the ends of the empty ducts, prior to installation of the OF Cable and shall be fitted immediately after laying the duct to prevent the entry of any dirt, water, moisture, insects/rodents etc. It should confirm to TEC GR No. TEC/GR/TX/CDS-008/03/MAR- 11 with latest amendments. The ends of the PLB HDPE ducts/coils laid in the manholes should be closed with End Caps. The End Caps used should be suitable for closing 40mm/33mm PLB HDPE ducts/coils. A suitable arrangement should be provided in the End Cap to tie PP Rope.

(See figure-1 for details)

d) Cable sealing Plug

This shall be used to seal the end of the ducts perfectly, after the OF cable is pulled in the duct. For pulling the cable through the ducts, it is necessary to provide man holes at that location and also at bends and corners wherever required. The ends of the PLB HDPE ducts/coils are closed with Cable sealing Plugs. The End Plugs used should be suitable for closing 40mm/33mm PLB HDPE ducts/coils. The Cable sealing plug shall confirm to TEC GR No. TEC/GR/TX/CDS- 008/03/MAR-11 with latest amendments. (Wherever blowing technique is used for laying OF Cable, at the discretion of the CPSUs concerned, the hand holes/manholes required for accessing the cable during cable laying can be at longer distances depending upon requirement.)

4.3.3. Material for Providing Additional Protection

a) RCC Full Round Pipes

Reinforced cement concrete pipes (spun type) coupled with RCC collars sealed with cement mortar used to provide additional protection to PLB HDPE Ducts/coils at lesser depths should be of full round, NP-2 class and size 100 mm (internal diameter), conforming to IS standard 458-1988 with latest amendments. The pipes should have a nominal length of 2 meters.

The RCC collars should be properly sealed using cement mortar 1:3 (1:53 grade cement of reputed brand, 3: fine sand without Impurities). If case of long spans, every third joint will be embedded in a concrete Area of size 60 cms (L) x 40 cms (W) x 25 cms (H) of 1:2:4 cement concrete mix (1: cement, 2: coarse sand, 4: stone aggregate of 20 mm nominal size) so that the alignment of RCC pipes remain firm and intact. Also, both ends of RCC pipes spans will be sealed by providing concrete block of size 40 cm (L) x 40 cm (W) x 25 cm (H) of 1:2:4 cement concrete mix to avoid entry of rodents.

b) RCC Split Pipes

OFC MTC. MARWAHI-PENDRA DISTRICT

The split Reinforced cement concrete pipes (spun type) with in-built collars are used to provide additional protection to PLB HDPE Ducts/coils should be of 100mm internal dia.(Spigotted), Class--NP-3, Thickness: 25mm, Length: 2Meters with inbuilt collar at one end, Conforming to ISI Specification IS: 458, 1988 with latest amendment

c) G.I. Pipes

G.I. pipes should be of medium duty class having inner diameter of 50mm and should conform to specifications as per IS 554/1985 (revised up to date) IS 1989 (Part-I), 1900 Sockets (revised upto date) & IS 1239 (Part-II) 1992 (revised up to date).

d) DWC Pipes

Use of normal duty DWC (Double walled corrugated) HDPE pipe – confirming to TEC GR no.GR/DWC-34/01 Sep.2007 with latest amendments shall be preferably utilized as first choice for protection of Optical Fiber Cable instead of GI pipes. The DWC pipes used shall be of size 75/56 mm as per table 2 of the said TEC GR.

e) M.S. Weld Mesh

The PLB HDPE Ducts can also be protected by embedding it in concrete of size of 25 cms x 25 cms reinforced with MS weld mesh. The MS weld mesh used should be of 50 mm x 100 mm size, 12 SWG, 120 cms in width in rolls of 50m each. One meter of MS weld mesh caters to approx. 3 meters of concreting. (See figure ‘2’ for details)

The strength of RCC/CC is dependent on proper curing; therefore, it is imperative that water content of CC/RCC mix does not drain out into the surrounding soil. In order to ensure this, the RCC/CC work should be carried out by covering all the sides by yellow PVC sheets of weight not less than 1 kg per 8 sqm to avoid seepage of water into the soil.

4.3.4. Joint Chamber

The Joint chamber shall be provided at every joint location to keep the OF cable joint well protected and also to house extra length of cable which may be required in the event of faults at a later date. The Joint chamber shall be of pre-cast RCC type as per construction specification. Brick chamber can also be made with prior permission of Engineer in-charge.

4.3.5. Rubber Bush

To prevent entry of rodents into PLB HDPE DUCTS, the ends of PLB HDPE DUCTS are sealed at every manhole and joint using rodent resistant hard rubber bush (cap) after optical fiber cable is Pulled. The rubber bush should be manufactured from hard rubber with grooves and holes to fit into 40 mm PLB HDPE DUCTS pipe, so that it should be able to prevent the entry of insects, rodents, mud, and rainwater into the PLB HDPE DUCTS pipe. It should conform to TEC GR with latest amendments.(see Figure-3).

4.3.6. Route/Joint Indicator

The Route/Joint indicators are co-located with each manhole/joint chamber. In addition Route indicators are also to be placed where route changes direction like road crossings etc. Either RCC/Pre-cast or Stone based route indicators can be used. The detailed specification and design of the same shall be as per construction specification. Generally, Stone Route indicators shall be used for the NOFN project

CONSTRUCTION SPECIFICATIONS

1. EXCAVATION OF TRENCHES

1.1. Trenching

1.1.1. Location and Alignment of the Trench

In built up areas, the trench will normally follow the foot-path of the road except where it may have to come to the edge of the carriage way cutting across road with specific permissions from the concerned authorities maintaining the road (such permissions shall be obtained by the department as per MOU signed with respective State Govt.). Outside the built up limits the trench will normally follow then boundary of the roadside land. However, where the road side land is full of burrow pits or a forestation or when the cable has to cross culverts/ bridges or streams, the trench may come closer to the road edge or in some cases, over the embankment or shoulder of the Road (permissions for such deviations for cutting the embankment as well as shoulder of the road shall be obtained).

The alignment of the trench will be decided by a responsible official of the CPSUs, not below the rank of a Junior Telecom Officer in case of BSNL and similar level in case of other CPSUs. Once the alignment is marked, no deviation from the alignment is permissible except with the approval of Engineer-in-charge. While marking the alignment only the centre line will be marked and the Contractor shall set out all other work to ensure that, the excavated trench is as straight as possible. The Contractor shall provide all necessary assistance and labour, at his own cost for marking the alignment. Contractor shall remove all bushes, undergrowth, stumps, rocks and other obstacles to facilitate marking the centre line without any extra charges. It is to be ensured that minimum amount of bushes and shrubs shall be removed to clear the way and the contractor shall give all, consideration to the preservation of the trees.

The line up of the trench must be such that PLB pipe(s) shall be laid in a straight line, both laterally as well as vertically except at locations where it has to necessarily take a bend because of change in the alignment or gradient of the trench, subject to the restrictions mentioned else where.

1.1.2. Line-Up

The line-up of the trench must be such that PLB HDPE Ducts shall be laid in a straight line except at locations where it has to necessarily take a bend because of change in the alignment or gradient of the trench, subject to the restrictions mentioned elsewhere.

1.2. Method of Excavation

In built up areas, the contractor shall resort to use of manual labour / HDD only to ensure no damage is caused to any underground or surface installations belonging to other public utility services and/or private parties.

However, along the Highways and cross country there shall be no objection to the Contractor resorting to mechanical means of excavation, provided that no underground installations exist in the path of excavation, if any, are damaged.

There shall be no objection to resort to horizontal boring to bore a hole of required size and to push through G.I. Pipe (50 mm ID) through horizontal bore at road crossing or rail crossing or small hillocks etc.

All excavation operations shall include excavation and 'getting out'. 'Getting out' shall include throwing the excavated materials at a distance of at least one meter or half the depth of excavation, whichever is more, clear off the edge of excavation. In all other cases 'getting out' shall include depositing the excavated materials as specified.

OFC MTC. MARWAHI-PENDRA DISTRICT

In Rocky strata excavation shall be carried out by use of electro mechanical means like breakers/ jack hammers or by blasting wherever permissible with express permission from the competent authority. If blasting operations are prohibited or not practicable, excavation in hard rock shall be done by chiseling/ jack hammers.

Trenching shall as far as possible be kept ahead of the laying of pipes. Contractor shall exercise due care that the soil from trenching intended to be loose for back filling is not mixed with loose debris.

While trenching, the Contractor should not cause damage to any underground installations belonging to other agencies and any damage caused should be made good at his own cost and expense.

Necessary barricades, night lamps, warning board and required watchman shall be provided by the contractor to prevent any accident to pedestrians or vehicles. While carrying out the blasting operations, the contractor shall ensure adequate safety by cautioning the vehicular and other traffic.

The contractor shall employ sufficient man-power for this with caution boards, flags, sign writings etc. The contractor should provide sufficient width at the trench at all such places, where it is likely to cave in due to soil conditions without any extra payment. A minimum free clearance of 15 cms. Should be maintained above or below any existing underground installation. No extra payment will be made towards this. In order to prevent damage to PLB HDPE DUCTS over a period of time, due to the growth of trees, roots, bushes, etc., the contractor shall cut them when encountered in the path of alignment of trench without any additional charges.

In large burrow pits, excavation may be required to be carried out for more than 165 cms in depth to keep gradient of bed less than 15 degrees with horizontal. If not possible as stated above, alignment of trench shall be changed to avoid burrow pit completely.

1.2. Depth and Size of the Trench

The depth of the trench from top of the surface shall not be less than 165 cms unless otherwise relaxation is granted by competent authority under genuine circumstances.

In rocky terrain, less depth shall be allowed only in exceptional circumstances with additional protection where it is not possible to achieve the normal depth due to harsh terrain/ adverse site conditions encountered.

This shall be done only with the approval of the competent authority and consent of the Engineer in-charge after following the laid down norms and procedures being followed in the CPSUs concerned.

This shall be properly documented. In all cases, the slope of the trench shall not be less than 15 degrees with the horizontal surface. The width of the trench shall normally be 45 cms at the top & 30 cms at the bottom.

In case, additional pipes (HDPE/GI/RCC Pipes) are to be laid in some stretches, the same shall be accommodated in this normal size trench.

When trenches are excavated in slopes, uneven ground, inclined portion, the lower edge shall be treated, as top surface of land and depth of trench will be measured accordingly. In certain locations, such as uneven ground, hilly areas and all other Places, due to any reason whatsoever it can be ordered to excavate beyond standard depth of 165 cms to keep the bed of the trench as smooth as possible. Near the culverts, both ends of the culverts shall be excavated more than 165 cms. to keep the gradient less than 15 degree with horizontal. For additional depth in excess of 165 cms., no additional payment shall be applicable.

If excavation is not possible to the minimum depth of 165 cms. As detailed above, full facts shall be brought to the notice of the Engineer in charge in writing giving details of location and reason for not being able to excavate that particular portion to the minimum depth. Approval shall be granted by the competent authority in writing under genuine circumstances. The decision of the competent authority

shall be final and binding on the contractor. All the relaxations granted as specified above shall be dealt with as per the laid down norms and procedure of CPSUs.

1.3.1. Dewatering: The Contractor shall be responsible for all necessary arrangements to remove or pump out water from trench. The Contractor should survey the soil conditions encountered in the section and make his own assessment about dewatering arrangement that may be necessary. No extra payment shall be admissible for this.

1.3.2. Wetting: Wherever the soil is hard due to dry weather conditions, if watering is to be done for wetting the soil to make it loose, the same shall be done by the contractor. No extra payment shall be admissible for this.

1.3.3. Blasting: For **excavation in hard rock**, where blasting operations are considered necessary, the contractor shall obtain approval of the Engineer-in-Charge in writing for resorting to blasting operation. The contractor shall obtain license from the competent authority for undertaking blasting work as well as for obtaining and storing the explosive as per the Explosive Act, 1884 as amended upto date and the explosive Rules, 1983. The contractor shall purchase the explosives fuses, detonators, etc. only from a licensed dealer. Transportation and storage of explosive at site shall conform to the aforesaid Explosive Act and Explosive Rules. The contractor shall be responsible for the safe custody and proper accounting of the explosive materials. Fuses and detonators shall be stored separately and away from the explosives. The Engineer-in-Charge or his authorized representative shall have the right to check the contractor's store and account of explosives. The contractor shall provide necessary facilities for this. The contractor shall be responsible for any damage arising out of accident to workmen, public or property due to storage, transportation and use of explosive during blasting operation. Blasting operations shall be carried out under the supervision of a responsible authorized agent of the contractor (referred subsequently as agent only), during specified hours as approved in writing by the Engineer-in-Charge. The agent shall be conversant with the rules of blasting. All procedures and safety precautions for the use of explosives drilling and loading of explosives before and after shot firing and disposal of explosives shall be taken by the contractor as detailed in **IS: 4081** safety code for blasting and related drilling operation.

1.3.4. Trenching near Culverts/ Bridges: The PLB HDPE Ducts shall be laid in the bed of culvert at the depth not less than 165 cms protected by RCC pipes as decided by Engineer-in charge. Both ends of culverts shall be excavated more than 165 cms in depth to keep the gradient of not less than 15 degree with horizontal. The bed of trench should be as smooth as possible.

1.3.5. While carrying out the work on bridges and culverts, adequate arrangement for cautioning the traffic by way of caution boards during day time and danger lights at night shall be provided. In case of small bridges and culverts, where there is a likelihood of their subsequent expansion and remodeling, the cable should be laid with some curve on both sides of the culvert or the bridge to make some extra length available for readjustment of the cable at the time of reconstruction of culvert or the bridge.

2. Laying OF PLB HDPE Ducts

After the trench is excavated to the specified depth, the bottom of the trench has to be cleared of all stones or pieces of rock and leveled up properly. A layer of soft soil/or sand (in case the excavated material contains sharp pieces of rock/stones) of not less than 5 cms is required for levelling the trench to ensure that the cable when laid will follow a straight alignment. Adequate care shall be exercised while laying so that the OF cables are not put to undue tension/pressure after being laid as this may adversely affect the optical characteristics of cables with passage of time.

The contractor shall ensure that trenching and pipe laying activities are continuous, without leaving patches or portions incomplete in between. In case intermediate patches are left, measurement of the completed portions will be taken only after work in such left over patches are also completed in all respects. Preparatory to aligning the pipe for jointing, each length of the PLB HDPE Ducts shall be thoroughly cleaned to remove all sand, dust or any other debris that may clog, disturb or damage the optical fibre cable when it is pulled at a later stage. The ends of each pipe and inside of each Socket shall be thoroughly cleaned of any dirt or other foreign materials.

After the trench is cleaned the PLB HDPE Ducts/Coil shall be laid in the cleaned trench, jointed with Sockets. Drawing up of PP rope is optional as per TEC GR. In case of use of PP Rope, at every manhole approximately at every 200m or at bends or turns the PP rope will be tied to the HDPE end caps used for sealing the PLB HDPE Ducts, to avoid entry of rodents/mud etc.

At the end of each day work, the open ends of the pipes sections shall be tightly closed with end caps to prevent the entry of dirt/mud, water or any foreign matter into PLB HDPE Ducts until the work is resumed. In built up area falling within Municipal/Corporation limits, the PLB HDPE Ducts shall be laid with protection using RCC Pipes/ Concreting reinforced with weld mesh (only in exceptional cases).

Providing Protection to the OFC:-

For lesser depths requiring additional protection in built up areas, towns and cities falling within the municipal limits, suitable protection shall be provided to PLB HDPE pipes/coils using RCC/DWC full round/split pipes or GI pipes or cement concreting reinforced with MS weld mesh or a combination of any of these as per the site requirement. This shall be done only with the prior instructions/approval of the Engineer-in-charge. The specifications for providing each of these protections are given later in this document.

Moreover, in cross country routes, if depth is less than 1.2 meters, protection by using RCC/DWC Pipe shall be provided. Engineer-in-Charges shall decide about such stretches and type of protection to be provided in view of the site requirements. Normally 100 mm RCC /DWC Pipes shall be used for protecting PLB HDPE Ducts but if more than one PLB pipe is to be laid and protected, RCC/DWC Pipe of suitable size to accommodate the required number of PLB Pipes shall be used.

The PLB HDPE Ducts shall be laid in RCC Full Round spun Pipes/GI Pipes as required at Road Crossings. The RCC pipes/GI pipes shall extend at least 3 meters on either side of the road at Road crossings. At Road crossings, extra GI/PLB HDPE Ducts may be laid as per the direction of The Engineer-in charge. On Rail bridges and crossings, the PLB HDPE Ducts shall be encased in Suitable cast iron as prescribed by the Railway Authorities.

Wherever RCC pipes are used for protection, the gaps between the RCC collars and the RCC pipes shall be sealed using cement mortar 1:3 (1:53 grade cement of reputed brand, 3: fine sand without impurities) to bar entry of rodents. Every third collar of RCC pipes (normally of 2 meters length) and also both ends of RCC Pipes will be embedded in a concrete block of size 40 cms (L)x 40 cms (W) x 25 cms (H) of 1:2:4 cement concrete mix (1:53 grade cement of reputed brand, 2: coarse sand, 3: stone aggregate of nominal size of 20 mm) so that the alignment of RCC pipes remain firm and intact and to avoid entry of rodents.

Wherever GI pipes are used, special care should be taken to ensure that G.I. Pipes are coupled properly with the sockets so as to avoid damage to PLB pipe and eventually the OF Cable in the event of pressure coming on the joint and G.I. Pipe joint giving its way. Rubber bushes shall be used at either ends of the GI pipes to protect PLB pipe. Both the ends of G.I. Pipe will be embedded in a concrete block of size 40 cms (L) x 40 cms ((W) x 25 cms (H) of 1:2:4 cement concrete mix (1:53 grade cement of reputed brand, 2: coarse sand, 3: stone aggregate of nominal size of 20 mm) so that the alignment of G.I. Pipes remain firm and intact and to avoid entry of rodents.

In case of protection by concreting at site, the nominal dimension of concreting shall be 250 mm x 250 mm section. Cement Concrete Mixture used shall be of 1:2:4 composition i.e. 1:53 grade Cement of a reputed company , 2: Coarse Sand, 4: Graded Coarse Stone aggregate of 20 mm nominal size, reinforced with MS weld mesh. As the RCC is cast at site, it is imperative to ensure that special care is taken to see that proper curing arrangements are made with adequate supply of water. The contractor shall invariably use mechanical mixer at site for providing RCC protection, to ensure consistency of the mix. For carrying out concreting work in trenches, yellow PVC sheets of width not less than 1.0 M and of weight not less than 1 kg. Per 8 sq. meters shall be spread and nailed on sides of the trench to form trapezoidal

OFC MTC. MARWAHI-PENDRA DISTRICT

section for concreting in the cleaned trench, to avoid seepage of water into the soil. A bed of cement concrete mixture of appropriate width and 75 mm thickness shall be laid on the PVC Sheet, before laying PLB HDPE ducts. The PLB HDPE Ducts shall then be laid above this bed of Concrete. After laying the PLB HDPE Ducts, MS weld mesh is wrapped around and tied and concrete mix is poured to form the cross sectional dimensions as instructed by the Engineer-in charge.

The strength of RCC is dependent on proper curing therefore; it is imperative that water content of RCC mix does not drain out into the surrounding soil. Portions where cement concreting has been carried out shall be cured with sufficient amount of water for reasonable time to harden the surface. After curing, refilling of the balance depth of the trench has to be carried out with excavated soil.

The PLB HDPE Ducts/RCC/GI Pipes shall be laid only in trenches accepted by Engineer-in-Charge or his representative. The Contractor shall exercise due care to ensure that the PLB HDPE Ducts are not subjected to any damage or strain.

Water present in the trench at the time of laying the PLB HDPE Ducts shall be pumped out by the contractor before laying the pipes in the trench to ensure that no mud or water gets into the pipes, thus choking it.

In case of nallahs, which are dry for nine months in a year, the PLB HDPE Ducts shall be laid inside the RCC Pipes laid at a minimum depth of 165 cms. as instructed by the Engineer-in-charge. The mechanical protection shall extend at least 5 meters beyond the bed of nallah on either side. Notwithstanding anything contained in clauses referred above, the Engineer-in-charge may order, based on special site requirements, that the PLB HDPE Ducts may be encased in reinforced cement concrete, as detailed, *ibid*. While laying the pipes, a gap of 2 M is kept at convenient locations approx. 200 m apart and at the bends and turns, which will be used as manholes during OF cable pulling. Ends of the PLB HDPE Ducts at the manholes shall be sealed using end caps after tying the PP rope to the end caps to avoid choking of the pipes. In a similar manner, manholes shall be kept while approaching bridges, road crossings etc., as instructed by the Engineer-in-charge. The location of the manholes will be decided by the Engineer-in-charge.

2.1. Laying Protection Pipes On Bridges And Culverts:

In case trenching and pipe laying is not possible on the culverts, the pipes shall be laid on the Surface of the culverts/bridges after due permission from the competent authority. Of late the bridge construction authorities are providing channel ducts on the footpaths on the bridges for various services. The RCC/DWC/ G.I. Pipes can be laid in these ducts for pulling cables. However, for laying cables on existing bridges, where duct arrangement does not exist, one of the following methods may be adopted.

a. In case of the Bridges/Culverts, where there are no ducts and where the cushion on the top of the Arch is 50 cm to 100 cm or more, G.I. Pipe (Carrying PLB HDPE pipe and cable) may be buried on the top of the Arch adjoining the parapet wall, by digging close to the wheel guards. Every precaution shall be taken to see that no damage occurs to the arch of the culvert. After burying the GI pipe, the excavated surface on the arch shall be restored.

b. Where the thickness of the Arch is less than 50 cms, the pipe must be buried under the wheel guard masonry and the wheel guard rebuilt.

c. If neither of the two methods is possible, the G.I. Pipes/GI Troughs must be clamped on the parapet wall with the clamps. If necessary, the pipes may be taken through the parapet wall at the ends where the wall diverges away from the road. Methods cited in above clauses should be carried out under close supervision of Road authorities.

The surface to be concreted should be thoroughly cleaned and leveled before concreting. At both ends of the Bridges/Culverts, where the GI Pipes /GI Troughs slope down and get buried, the concreting should

be extended sufficiently to ensure that no portion of the GI Pipes/GI Troughs is exposed as approved by the Engineer- in- charge to protect the pipe/trough from any possible externally caused damage.

Where white wash/colour wash exists on the Bridges/ Culverts, the same should also be carried out on the concreted portion to ensure uniformity.

3. Back Filling and Dressing of the Trench

Provided that the PLB HDPE pipes have been properly laid in the trench at the specified depth, the back filling operation shall follow as early as practicable. The earth used for filling shall be free from all roots, Grass, shrubs, vegetation, trees, saplings and any other kind of garbage or pebbles. The back filling operation shall be performed in such a manner so as to provide firm support under and above the pipes and to avoid bend or deformation of the PLB HDPE pipes when the pipes get loaded with the back filled earth. At locations where the back filled materials contains stones/sharp objects which may cause injury to the PLB HDPE pipes and where the excavated or rock fragments are intended to refill the trench in whole or in part, the trench should be initially filled, with a layer of ordinary soil or loose earth (free from any stones/pebbles) not less than 10 cms thick over the pipes. Back filling on public, roads, railway crossings, footpaths in city areas shall be performed immediately after laying the HDPE pipes. Back filling at such locations shall be thoroughly rammed, so as to ensure original condition so that it is safe for the road traffic. All excess soil/ material left on road/ footpath/railway crossing shall be removed by contractor. However, along the highways and in country side, the excess dug up material left over after refilling should be kept in a heap above over the trench. In city limits, at any given time more than 50 Meters length of trench should be kept open and in all places where excavation has been done, no part of the trench should be kept open over night to avoid occurrence of any mishap or accident in darkness.

4. CABLE PULLING AND JOINING/SPLICING

4.1. CABLE PULLING

Manholes marked during PLB HDPE Ducts pipe laying of approx. Size of 2.0 m length x 1.0 m width x 1.65 m depth shall be excavated for pulling the cables. There may be situations where addition manholes are required to be excavated, for some reasons, to facilitate smooth pulling of cable. Excavation of addition manholes will be carried out, without any extra cost. De-watering of the manhole, if required, will be carried out without any extra costs. Dewatering/ De-gasification of the Ducts, if required, will be carried out without any extra costs.

The Optical Fibre cables are available in drums in lengths of approx. 2 kms. The cables shall be blown /manually pulled (in exceptional cases) through already laid PLB HDPE DUCTS. This work is to be carried out under the strict supervision of site in-charge. It shall be ensured that during the blowing / pulling of Cable the tension is minimum and there is no damage to the Cable/Optical fibers. After pulling of the drum is completed, both ends of the PLB HDPE DUCTS pipe in each Manhole should be sealed by hard rodent resistant rubber bush, to avoid entry of rodents/mud into PLB HDPE Ducts.

The Manholes are prepared by providing 40 mm split PLB HDPE DUCTS pipe of 2.5 to 3m length and closing the split PLB HDPE Ducts by providing necessary clamps/ adhesive tape as per the directions of Engineer-in- charge. Afterwards, the split/cut PLB HDPE DUCTS pipe are covered with 100 mm split RCC pipe of 2m length and sealing the ends of RCC pipe with lean cement solution for protecting bare cable in the manhole . After fixing of RCC Split Pipes necessary back filling/reinstatement and dressing of manholes should be carried out as referred under trenching. The location of the pulling manhole should be recorded for preparation of documentation.

4.2. Jointing/ Splicing

Optical Fiber Cable Joints will be at varying distances depending upon the incremental fiber to be laid for connecting Panchayats. The 24 fibers are to be spliced at every Joint & at both ends (Terminations) in the equipment room as directed by the Engineer-in-charge. The Infrastructure required for cable splicing i.e.

- Splicing machine
- OTDR
- Optical talk set
- Tool kit etc.

will be arranged by the vender and also any additional accessories. e.g. Engine etc. required at site for splicing will also be arranged by the vender. The Optical Fiber Cable thus jointed end-to-end will be tested by an officer of Acceptance Testing unit of the concerned CPSUs for splice losses and transmission parameters as specified by and prevalent at that time. The through Optical Fibre should meet all the technical parameters, specified and no relaxation will be granted.

5. Construction of Jointing Chamber:

The joint chambers are provided at every joint to keep the O.F.C. joint well protected and also to keep extra length of cable, which may be, required to attend the faults at a later date. Jointing chambers are to be prepared at the Fiber Point of Interconnect (FPIO) or normally at distance of every 2 kms. Actual location of jointing chamber depends on length of cable drum and appropriateness of location for carrying out jointing work. The location is finalized by Engineer-in-charge. The jointing chambers are constructed by way of fixing pre-cast RCC chambers/Brick Chambers and covers as per the instructions from Engineer-in-charge.

5.1. Pre cast RCC chamber

For fixing pre cast RCC chamber, first a pit of size 2 m x 2 m x 1.8 m depth shall be required to be dug. Pre cast RCC chamber shall consist of three parts (i) round base plate of 140 cm diameter and 5 cm thickness in two halves (ii) full round RCC joint chamber with diameter of 120 cm and height of 50 cm and thickness of 5 cm (iii) round top cover will be in two halves with diameter of 140 cm and thickness of 5 cm having one handle for each half in centre and word 'OFC' engraved on it. (See figure '4'). After, fixing the pre cast RCC joint chamber, the joint chamber is filled with clean sand before closing. Back filling of joint chamber pit with excavated soil shall be carried out in the end.

5.2. Brick Chamber

For constructing brick chamber, first a pit of size 2m x2 mx1.8 m depth is shall be required to be dug. Then, base of the chamber shall be made using concrete mix of 1:5:10 (1 cement, 5 coarse sand, 10 graded stone aggregate of 40mm nominal size) of size of 1.7m x 1.7 m and 0.15 m thickness. Wall of brick chamber should be constructed on this base having wall thickness of 9" using cement mortar mix of 1:5 (1: cement, 5: fine sand). The chamber should have internal dimensions of 1.2 m x 1.2 m and 1 m height. The bricks to be used for this purpose should be of size 9" x 4.5" x 3", best quality available and should have smooth rectangular shape with sharp corners and shall be uniform in colour and emit clear ringing sound when struck. The joint chamber should be so constructed that PLB pipe ends remain protruding minimum 5 cms inside the chamber on completion of plastering. The PLB pipes should be embedded in wall in such a way that, the bottom brick should support the pipe and upper brick should be provided in a manner that PLB HDPE pipe remains free from the weight of the construction. The joint chamber should be plastered on all internal surfaces and top edges with cement mortar of 1:3 (1: cement, 3: coarse sand), 12 mm thick finished with a floating coat of complete cement as per standard. Pre-cast RCC slab with two handles to facilitate easy lifting, of size 0.7 m x 1.4 m and of thickness of 5 cm having one handle for each half in centre and word 'OFC' engraved on it are to be used to cover the joint chamber. Two numbers of such slabs are required for one joint chamber. This pre-cast slab should be made of cement concrete mix of 1:2:4 (1: cement, 2: coarse sand, 4: stone aggregate 6 mm nominal size) reinforced with steel wire fabric 75 x 25 mm mesh of weight not less than 7.75 Kg per sq. Meter. The joint chamber is filled with clean sand before closing. Back filling of joint chamber pit with excavated soil shall be carried out in the end

6. Fixing of Route Indicators / Joint Indicators

Pits shall be dug 500 cm to 1000 cm towards jungle side at every Manhole and Jointing chamber for fixing of Route/Joint Indicator. In addition, Route Indicators are also required to be placed where O.F. Cable changes directions like road crossing etc.

The pits for fixing the indicator shall be dug for a size of 60 cms. x 60 cms. and 75 cms. (Depth).The indicator shall be secured in upright position by ramming with stone and murrum upto a depth of 60 cms. And concreting in the ratio of 1:2:4 (1: cement, 2: coarse sand, 4 stone aggregate 20 mm nominal size) for the remaining portion of 15 cms. Necessary curing shall be carried out for the concreted structure with sufficient amount of water for reasonable time to harden the structure.

6.1. RCC/Pre cast Route Indicators

The route /joint indicator made of pre-cast RCC should have the following dimensions (see Figure '5')

Base - 250 mm x 150 mm

Top - 200 mm x 75 mm

Height - 1250 mm

6.2. Stone based Route Indicators

The route /joint indicators made of Sand/lime Stone Should have the following dimension
The word 'OFC' should be engraved on the Route/Joint indicators.

- i. Stone to be used (Sand/lime Stone)
- ii. Indicator Top surface to be rounded
- iii. Base 155 mm × 100 mm
- iv. Upper 500 mm length to be Tapered width wise as shown in the drawing and homogeneously finished.
- v. Height 650mm (Straight) + 400 mm (Tapered)
- vi. The route indicators should be engraved with word 'OFC' of size 80mm length & 50mm, Width.
- vii. Length 3.5 Ft., top 4"x4" dressed 1Ft. from top & tapered.

(See figure '6' for details of Stone Route Indicators)

The Route indicators shall painted Blue and placed at 500 to 1000 cm away from the centre of the trench towards jungle side. The Joint indicators are placed at OFC joints and placed 500 to 1000 cm Away from wall of the joint chamber facing jungle side and are painted Grey. The engraved word "OFC" should be painted in white, on route as well as joint indicators. Numbering of route indicators/joint indicators should also be done in white paint. The numbering scheme for route indicators will be Joint No. /Route Indicator No. for that joint. For example, 2/6 marking on a route indicator means 6th route indicator after 2nd joint. Additional joints on account of faults at a later date should be given number of preceding joint with suffix A, B, C, and D. For example sign writing 2A on a joint indicator means, additional joint between joint No. 2 and 3. The numbering of existing route/joint indicator should not be disturbed on account of additional joints. Enamel paints of reputed brand should be used for painting and sign writing of route as well joint indicators.

The route and joint indicator shall be painted with primer before painting with oil paint. The material used should bear ISI mark. The size of each written letter should be at least 3.5 cms. The colours of painting and sign writing is as under:

- (1) For Joint Indicator: Grey colour
- (2) For Route Indicator: Blue colour
- (3) For OFC & Nos: White colour.

7. Documentation

The documentation, consisting of the following shall be prepared for each Area and the Panchayats connected to the Block. 6 sets of documentation shall be provided both in Electronic format on CD as well as Hard binded copy.

7.1. Route Index Diagrams – General: This diagram shall consist of Cable Route Details on Geographical Map drawn to scale with prominent land marks and alignment of cable with reference to road. This shall be prepared on A-3 sheets of 80 GSM.

7.2. Route Index Diagrams –Profile

These diagrams will contain

- Make and size of the cable.
- Offset of cable from centre of the road at every 10 meters
- Depth profile of Cable at every 10 meter;
- Details of protection with type of protection depicted on it;
- Location of culvert and bridges with their lengths and scheme of laying of PLB HDPE

Ducts pipe thereon.

- Important landmarks to facilitated locating the cable in future; Location of Joints and pulling manholes.

These diagrams shall be prepared on **A-4 sheets** of 80 GSM. On one sheet profile of maximum 400 meters shall be given to ensure clarity.

7.3. Joint Location Diagram

This diagram will show

- Geographical location of all the joints.
- Depth of Joint Chamber covers from ground level
- Type of chamber (Brick/Precast)
- Length of O.F. Cable kept inside the joint chamber from either direction.

This shall be prepared on A-4 sheets of 80 GSM.

All the diagrams (i), (ii) & (iii) shall bear the signatures of the contractor, the Engineer-in-charge as a proof of accuracy of the details. The diagrams shall be bound in A-4 size book with cover. The cover sheets shall be of 110 GSM and laminated. The front cover shall have the following details.

1. Name of the State/District/Block
2. Name of the Panchayats connected
3. Name of the with logo
4. Name of the CPSU executing the work
5. Name of the Contractor
6. Date of commencement of work
7. Date of completion of work

For each Area 1 sets of above mentioned document shall be submitted to .

8. SAFETY PRECAUTIONS

8.1. Safety Precautions when excavating or working in excavations close to electric cables

The Engineer- in-charge of the work should get full information from Electricity undertaking regarding any electric cables, which are known or suspected to exist near the proposed excavation and unless this is done, excavation should not be carried out in the section concerned.

The electricity undertaking should be asked to send a representative and work should be preceded with close consultation with them.

Only wooden handled hand tools should be used until the electric cables have been completely exposed. Power Cables, not laid in conduits, are usually protected from above by a cover slab of concrete, brick or stone. They may or may not be protected on the sides. It is safer, therefore, always to drive the point of the pickaxe downwards then uncovering a cable, so that there is less chance of missing such warning slabs. No workman should be permitted to work alone where there are electric cables involved. At least one more man should be working near by so that help can be given quickly in case of an accident. If disconnection of power could be arranged in that section it will be better. No electric cables shall be moved or altered without the consent of the Electric Authority and they should be contacted to do the needful. If an electric cable is damaged even slightly, it should be reported to the Electric Authority and any warning bricks disturbed during excavation should be replaced while back filling the trench. Before driving a spike into the ground, the presence of other underground properties should be checked. Information on plans regarding the location of power cables need not to be assumed as wholly accurate. Full precautions should be taken in the vicinity until the power cable is uncovered. All electric cables should be regarded as being live and consequently dangerous. Any power is generally dangerous, even low voltage proving fatal in several cases.

8.2. Electric shock-Action and treatment:

Free the victim from the contact as quickly as possible. He should be jerked away from the live conductors by dry timber, dry rope or dry clothing. Care should be taken not to touch with bare hands as his body may be energized while in contact. Artificial respiration should begin immediately to restore breathing even if life appears to be extinct. Every moment of delay is serious, so, in the meanwhile, a doctor should be called for.

8.3. Safety Precautions while working in Public Street and along railway lines:

Where a road or footpath is to be opened up in the course of work, special care should be taken to see that proper protection is provided to prevent any accidents from occurring. Excavation work should be done in such a manner that it will not unduly cause inconvenience to pedestrians or occupants of buildings or obstruct road traffic. Suitable bridges over open trenches should be so planned that these are required for the minimum possible time. Where bridges are constructed to accommodate vehicular traffic and is done near or on railway property, it should be with the full consent and knowledge of the competent railway authorities.

8.4. Danger from falling material

Care should be taken to see that apparatus, tools or other excavating implements or excavated Materials are not left in a dangerous or insecure position so as to fall or be knocked into the trench thereby injuring any workman who may be working inside the trench.

8.5. Care when working in Excavations

Jumping into a trench is dangerous. If it is deep, workmen should be encouraged to lower themselves. Workers should work at safe distance so as to avoid striking each other accidentally with tools. If the walls of the trench contain glass bits, corroded wire or sharp objects they should be removed carefully. If an obstruction is encountered, it should be carefully uncovered and protected if necessary. Care must be taken to see that excavated material is not left in such a position that it is likely to cause any accident or obstruction to a roadway or waterway. If possible the excavated material should be put between the workmen and the traffic without encroaching too much on the road.

8.6. Danger of cave in

When working in deep trenches in loose soil, timbering up/shoring the sides will prevent soil subsidence. The excavated material should be kept at sufficient distance from the edge of the trench or pit. Vehicles or heavy equipment must not be permitted to approach too close to the excavation. When making tunneled opening, it should be ensured that the soil is compact enough to prevent cave in even under

adverse conditions of traffic. Extra care should be taken while excavating near the foundations of buildings or retaining walls. In such cases, excavation should be done gradually and as far as possible in the presence of the owners of the property.

8.7. Protection of Excavations:

Excavations in populated areas, which are not likely to be filled up on the same day should be protected by barriers or other effective means of preventing accidents and the location of all such openings must in any event be indicated by red flags or other suitable warning signs. During the hours from dusk to dawn, adequate number of red warning lamps should be displayed. Supervisory officers should ensure that all excavations are adequately protected in this manner as serious risk and responsibility is involved. Notwithstanding adoption of the above mentioned precautions, works involving excavations should be so arranged as to keep the extent of opened ground and the time to open it to a minimum.

8.8. Precautions while working on roads

The period between half an hour after sun-set and half an hour before sunrise, and any period of fog or abnormal darkness may also be considered as night for the purpose of these instructions, for the purpose of providing the warning signs. Excavation liable to cause danger to vehicles or the public must at all times be protected with fencing of rope tied to strong uprights or bamboo poles at a suitable height or by some other effective means. Any such temporary erection which is likely to cause obstructions and which is not readily visible should be marked by posts carrying red flags or boards with a red background by day and by continuously lighted lamps at night.

The flags and the lamps should be placed in conspicuous positions so as to indicate the pedestrians and drivers of vehicles the full expanse i.e. both width and length of the obstruction. The distance between lamps or between floors should not generally exceed 1.25 m along the width and 6m along length of the obstruction in non-congested areas, but 4 meters along the length in congested areas. If the excavation is extensive, sufficient notice to give adequate warning of the danger should be displayed conspicuously not less than 1.25 m above the ground and close to the excavation. Where any excavation is not clearly visible for a distance of 25m to traffic approaching from any direction or any part of the carriage way of the road in which the excavation exists, a warning notice should be placed on the kerb or edge of all such roads from which the excavation or as near the distance as is practicable but not less than 10 m from the junction of an entering or intersecting road in which the excavation exists. All warnings, in these should have a red background and should be clearly visible and legible. All warning lamps should exhibit a red light, but white lights may be used in addition to facilitate working at night. Wherever required a passage for pedestrians with footbridge should be provided. At excavations, cable drums, tools and all materials likely to offer obstructions should be properly folded round and protected. This applies to jointer's tents as well. Leads, hoses etc. stretched and across the carriageway should be guarded adequately for their own protection and also that of the public.

8.9. Traffic Control

The police authorities are normally responsible for the control of traffic and may require the setting up of traffic controls to reduce the inconvenience occasioned by establishment of a single line of traffic due to restriction in road width or any other form of obstruction caused by the work. As far as possible, such arrangements should be settled in advance. If there are any specific regulations imposed by the local authorities, these should be followed.

8.10. Work along Railway Lines

Normally all works at Railway crossing is to be done under supervision of the railway authorities concerned, but it is to be borne in mind that use of white, red or green flags by the Departmental staff is positively forbidden to be used when working along a railway line as this practice may cause an accident through engine drivers mistaking them for railway signals. When working along a double line of railway,

the men should be warned to keep a sharp look on both the “UP” and ‘DOWN” lines to avoid the possibility of any accident when trains pass or happen to cross one another near the work spot.

8.11. Procedure and Safety Precautions for use of explosives during blasting for trenching:

In areas where the cable trench cannot be done manually on account of boulders and rocks, it is necessary to blast the rocks by using suitable explosives. The quality of explosive to be used depends on the nature of the rocks and the kind of boulders. A few types of explosive fuses and detonators normally used for making trenches for cable works are detailed below:

- i) Gun powder
- ii) Nitrate Mixture
- iii) Gilatine
- iv) Safety fuses
- v) Electric Detonator
- vi) Ordinary Detonator

8.11.1. Procedure

A detailed survey of the route is to be done to assess the length of the section where trenching is to be done with the help of blasting. A route diagram of the rocky section may be prepared indicating the length of the route where the explosives are to be used. For the purpose of obtaining license, a longer length of route should be given in the application as in many cases, after digging; rocks appear which was not initially anticipated.

Next a license will have to be obtained for use and storing of explosive in that section. If the area falls under a police commissioner, the authority for granting such license is the police commissioner of the concerned area. When the route does not fall in the jurisdiction of a police commissioner, the authority for issuing license is the District Magistrate. The concerned authority should be applied in prescribed form with a route map. The concerned authority will make an enquiry and issue license for using/storing explosives for cables trenching work. Such license will be valid for 15 days only. The license should be got renewed if the blasting operation needs to be extended. Once the license is granted, it is the responsibility of the holders of the license for the proper use of explosives, its transportation and storing.

8.11.2. Method of using

The safest explosive is the Gelatin and electric detonator. Gelatin is in the form of a stick. Electric detonator is a type of fuse used for firing the explosive electrically. Holes are made at suitable intervals on rocky terrain or boulders either by air compressor or by manual chipping. The depth of the holes should be 2 to 3 ft. Fill up the holes with small quantity of sand for about 6”. First the electric detonator is to be inserted into the Gelatin and the Gelatin is to be inserted into the holes keeping the + ve and- ve wirings of electric detonators outside the holes. Again refill the holes with sand. These +ve and-ve insulated wires of detonator are then extended and finally connected to an EXPLODER kept at a distance of not less than 100 m. Now the explosive is ready for blasting. But, before connecting wires to exploder for blasting, all necessary precautions for stopping the traffic, use of red flags, exchange of caution signals, etc. Should be completed and only then Exploder should be connected and operated.

8.11.3. Operation of exploder (IDL Schaffer type 350 type exploder)

The type 350 blasting machine consists of a bearing Area with blasting machine system and the explosion proof light- alloy injection molded housing. The exploder is held with the left hand. The twist handle is applied to the drive pin, clapped with the right hand turned in the clock wise direction in continuous measurements at the highest speed from the initial position until it reached to a stop. At this stage an indication lamp will glow. When the indication lamp glows, “press button switch” should be pressed. This will extend the electric current to detonator and Gelatin will be detonated. The rock will be blasted out of the trench. Number of holes can be blasted in a single stroke by connecting all such detonators in series connection and finally to the exploder. After blasting, again mazdoors are engaged on the work to clear the debris. If the result of the first blasting is not satisfactory, it should be repeated again on the same place.

8.11.4. Warning

There may be two reasons for unsatisfactory results of the blasting

- a) Misfire of Gilatine due to leakage of current from detonator.
- b) Over loading because of overburdens. Never pull the broken wire pieces form the holes in such cases. Attempt should not be made to reblast the misfired Gilatine. The safest way is to make a fresh hole by its side and put fresh Gilatine in that hole and blast it.

8.11.5. Precautions

The abstract of Explosives Rules 1983 which are relevant to our work is given below:

8.12. Restriction of delivery and dispatch of explosives

No person shall deliver or dispatch any explosives to anyone other than a person who.

- a) is the holder of a license to possess the explosives or the agent of a holder of such a license duly authorized by him in writing on his behalf.

OR

- b) is entitled under these rules to possess the explosives without a license.

The explosives so delivered or dispatched shall in no case exceed the quantity, which the person to whom they are delivered or dispatched is authorized to possess with or without a license under these rules.

No person shall receive explosives form any person other than the holder of a license granted under these rules. No person shall receive from or transfer explosives to any person for a temporary storage or safe custody in a licensed premise unless prior approval is obtained from the Chief Controller. A person holding license for possession of explosives granted under these rules shall store the explosives only in premised specified in the license.

8.13. Protection from Lightening During Storing

Every magazine shall have attached there to one or more efficient lightening conductors designed and erected in accordance with the specification laid down in Indian Standard Specifications No.2309 as amended from time to time. The connections to various parts of earth resistance of the lightening conductor terminal on the building to the earth shall be tested at least once in every year by a qualified electrical engineer or any other competent person holding a certificate of competency in this behalf from the State Electricity Department. A certificate showing the results of such tests and the date of the last test shall be hung up in conspicuous place in the building.

8.14. Precautions during thunder-storm

When a thunder- storm appears to be imminent in the vicinity of a magazine or store house every person engaged in or around such magazine and store house shall be withdrawn to a safe distance from such magazine or store house and the magazine and store house shall be kept closed and locked until the thunder storm has ceased or the threat of it has passed.

8.15. Maintenance of records

Every person holding a license granted under these rules for possession, sale or use of explosives shall maintain records in the prescribed form and shall produce such record on demand to an Inspection Officer.

8.16. Explosives not to be kept in damaged boxes

The licensee of every magazine or store house shall ensure that, the explosives are always kept in their original outer package. In case, the outer package gets damaged so that the explosive contained therein cannot be stored or transported, such explosives shall be repacked only after the same are examined by controller of explosives.

8.17. Storage of explosives in excess of the licensed quantity

The quantity of any kind of explosives kept in any licensed magazine or store house shall not exceed the quantity entered in the license against such kind of explosives. No explosives in excess of the licensed quantity shall be stored in the magazine or store house unless a permit in this behalf is obtained from the licensing authority by a letter or telegram.

8.18. Precautions to be observed at Site

The electric power at the blasting site shall be discontinued as far as practicable before charging the explosives. No work other than that associated with the charging operations shall be carried out within 10 meters of the holes unless otherwise specified to the contrary by the licensing authority.

When charging is completed, any surplus explosive detonators and fuses shall be removed from the vicinity of the hole and stored at a distance which should prevent accidental detonation in the event of a charge detonating prematurely in any hole. The holes which have been charged with explosive shall not be left unattended till the blasting is completed. Care shall be taken to ensure that fuse or wires connected to the detonation are not damaged during the placing of stemming materials and tamping.

8.19. Suitable warning procedure to be maintained

The licensee or a person appointed by the licensee to be in charge of the use of explosives at the site shall lay down a clear warning procedure consisting of warning signs and suitable signals and all persons employed in the area shall be made fully conversant with such signs and signals.

8.20. Precautions to be observed while firing

The end of the safety fuse (if used in place of a detonator should be freshly cut before being lighted. The exploders shall be regularly tested and maintained in a fit condition for use in firing. An exploder shall not be used for firing a circuit above its rated capacity. The electric circuits shall be tested for continuity before firing. All persons other than the shot-firer and his assistant, if any, shall be withdrawn from the site before testing the continuity. For the purpose of jointing, the ends of all wires and cables should have the insulation removed for a maximum length of 5 cms. and should, then be made clear and bright for a minimum length of 2.5 cms. and the ends to be joined should be twisted together so as to have a positive metal contact.

Then these should be taped with insulation to avoid leakage when in contact with earth. In case of blasting with dynamite or any other high explosive, the position of all the bore holes to be drilled shall be marked in circles with white paint. These shall be inspected by the Contractor's agent. Bore holes shall be of a size that the cartridge can easily pass down. After the drilling operation, the agent shall inspect the holes to ensure that drilling has been done only at the marked locations and no extra hole has been drilled. The agent shall then prepare the necessary charge separately for each bore hole. The bore holes shall be thoroughly cleaned before a Cartridge is inserted. Only cylindrical wooden tamping rods shall be used for tamping. Metal rods or rods having pointed end shall never be used for tamping. One cartridge shall be placed in the bore hole and gently pressed but not rammed down. Other cartridges shall then be added as may be required to make up the necessary charge for the bore hole. The top most cartridges shall be connected to the detonator which shall in turn be connected to the safety fuses of required length. All fuses shall be cut to the length required before being inserted into the holes. Joints in fuses shall be avoided.

Where joints are unavoidable, a semi-circular niche shall be cut in one piece inserted into the niche. The two pieces shall then be wrapped together with string. All joints exposed to dampness shall be wrapped with rubber tape.

The maximum of eight bore holes shall be loaded and fired at one occasion. The charges shall be fired successively and not simultaneously. Immediately before firing, warning shall be given and the agent

OFC MTC. MARWAHI-PENDRA DISTRICT

shall see that all persons have retired to a place of safety. The fuses of the charged holes shall be ignited in the presence of the agent, who shall see that all the fuses are properly ignited.

Careful count shall be kept by the agent and other of each blast as it explodes. In case all the charged bore holes have exploded, the agent shall inspect the site soon after the blast but in case of misfire the agent shall inspect the site after half an hour and mark red crosses (X) over the holes which have not exploded. During this interval of half an hour, nobody shall approach the misfired holes. No driller shall work near such bore until either of the following operations has been done by the agent for the misfired boreholes.

- i.** The contractor's agent shall very carefully (when the tamping is damp clay) extract the tamping with a wooden scraper and withdraw the primer and detonator.
- ii.** The holes shall be cleaned for 30 cm of tamping and its direction ascertained by placing a stick in the hole. Another hole shall then be drilled 15 cm away and parallel to it. This hole shall be charged and fired. The misfired holes shall also explode along with the new one.

Before leaving the site of work, the agent of one shift shall inform the another agent relieving him for the next shift, of any case of misfire and each such location shall be jointly inspected and the action to be taken in the matter shall be explained to the relieving agent.

The Engineer-in-charge shall also be informed by the agent of all cases of misfire, their cause and steps taken in that connection.

8.21. General Precautions

For the safety of persons red flags shall be prominently displayed around the area where blasting operations are to be carried out. All the workers at site, except those who actually ignite the fuse, shall withdraw to a safe distance of at least 200 meter from the blasting site. Audio warning by blowing whistle shall be given before igniting the fuse.

Blasting work shall be done under careful supervision and trained personnel shall be employed.

Blasting shall not be done within 200 meters of an existing structure, unless specifically permitted by the Engineer-in-Charge in writing.

8.22. Precautions against misfire

The safety fuse shall be cut in an oblique direction with a knife. All saw dust shall be cleared from inside of the detonator. This can be done by blowing down the detonator and tapping the open end. No tools shall be inserted into the detonator for this purpose. If there is water present or if the borehole is damp, the junction of the fuse and detonator shall be made water tight by means of tough grease or any other suitable material. The detonator shall be inserted into the cartridge so that about one-third of the copper tube is left exposed outside the explosive. The safety fuse just above the detonator shall be securely tied in position in the cartridge. Waster proof fuse only shall be used in the damp borehole or when water is present in the borehole. If a misfire has been found to be due to defective fuse, detonator or dynamite, the entire consignment from which the fuse, detonator or dynamite was taken shall be got inspected by the Engineer-in-Charge or his authorized representative before resuming the blasting or returning the consignment.

8.23. Precaution against stray currents:

Where electrically operated equipments is used in locations having conductive ground or continuous metal objects, tests shall be made for stray current to ensure that electrical firing can proceed safely.

9. ALLIED ACTIVITIES

9.1. Transportation of Materials: The materials required for executing the work entrusted to the contractors against a work order shall be made available at Project Store Depot. In some cases the materials may be available at sub divisional store godown. The contractor shall be responsible for transporting the materials, to be supplied by the or otherwise to executethe work under the contract, to site at his/ their own cost. The costs of transportation are subsumed in the standard Schedule Rates and therefore no separate charges are payable on this account.

9.2. Disposal of Empty Cable Drums: The contractor shall be responsible to dispose of the empty cable drums after laying of the cables. The cost of various sizes of empty cable drums recoverable from the contractor has been fixed taking into account the prevailing market rates as mentioned in this document.

9.3. It shall be obligatory on part of the contractor to dispose of the empty cable drums at his/their level and the amount fixed for various empty cable drums shall be recovered from the bill for the work for which the drum (s) was/were issued or from any other amount due to the contractor or the Security Deposit.

9.4. The contractor shall not be allowed to dump the empty cable drums in Govt./Public place which may cause inconvenience to the / public. If the contractor does not dispose of the empty cable drums within 3 days of becoming it empty, the shall be at liberty to dispose off the drums in any manner deemed fit and also recover the amount fixed in this contract from the bill/security deposit/ any other amount due to the contractor.

9.5. Supply of Materials: There are some materials required to be supplied by the contractor for execution of work under this contract like jointing sleeves, Bricks, Cement, Wire Mesh and Steel for protection, etc., besides using other consumables which do/don't become the part of the asset. The contractor shall ensure that the materials supplied are of best quality and workmanship and shall be strictly in a accordance with the specifications.

Figure 2
M.S. WELDMESH

DETAILS OF 100 MM X 50 MM, 12 SWG MILD STEEL WELD MESH HAVING WIDTH OF 120 CM

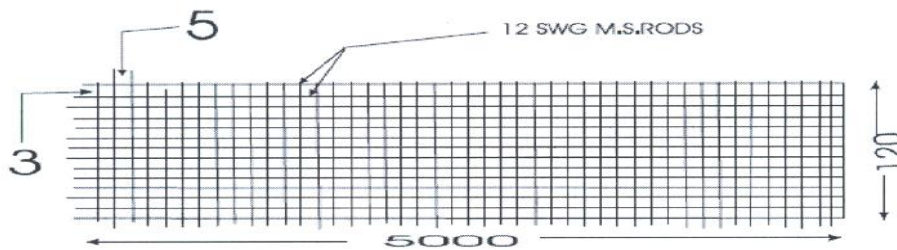

Note : All measurements are in centimeters.

Figure4
SPECIFICATION AND REINFORCEMENT DETAILSOFR.C.C. JOINT
PROTECTING CHEMBERS

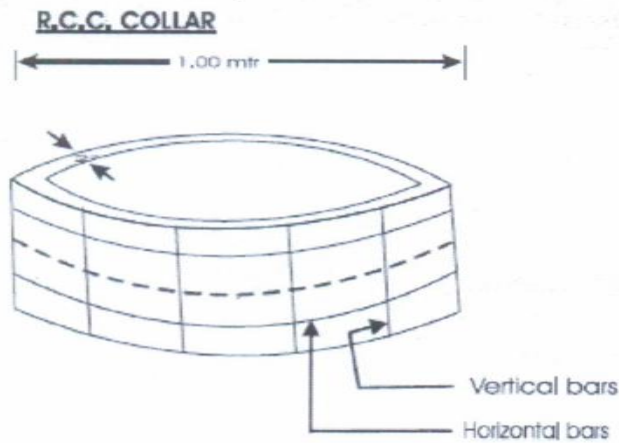

Specification :

1. Diameter : 1.00 Mtr.(inner side)
2. Thickness : 5 cm.
3. Height : 50 cm.
4. 6 mm Horizontal Iron round rings – 4 Nos.
5. 6 mm vertical bars Iron – 12 mm Nos.
6. 12 gauge GI wire mesh to be wrapped before reinforcing the concrete.

Note:

- a)Concrete 'Mix'. 1:2:3 (1 cement : 2 Sand : 3 graded Stone aggregate 20 mm nominal size.
- b)Finishing : Smooth

Specification

1. Diameter : 1.00 Mtr. (inner side)
2. Thickness : 5 cm
3. Height :50 cm
4. 6 mm Horizontal Iron round rings – 4 Nos.
5. 6 mm vertical bars Iron – 12 mm Nos.
6. 12 gauge GI wire mesh to be wrapped before reinforcing the concrete.

Figure 5
RCC Route Indicator

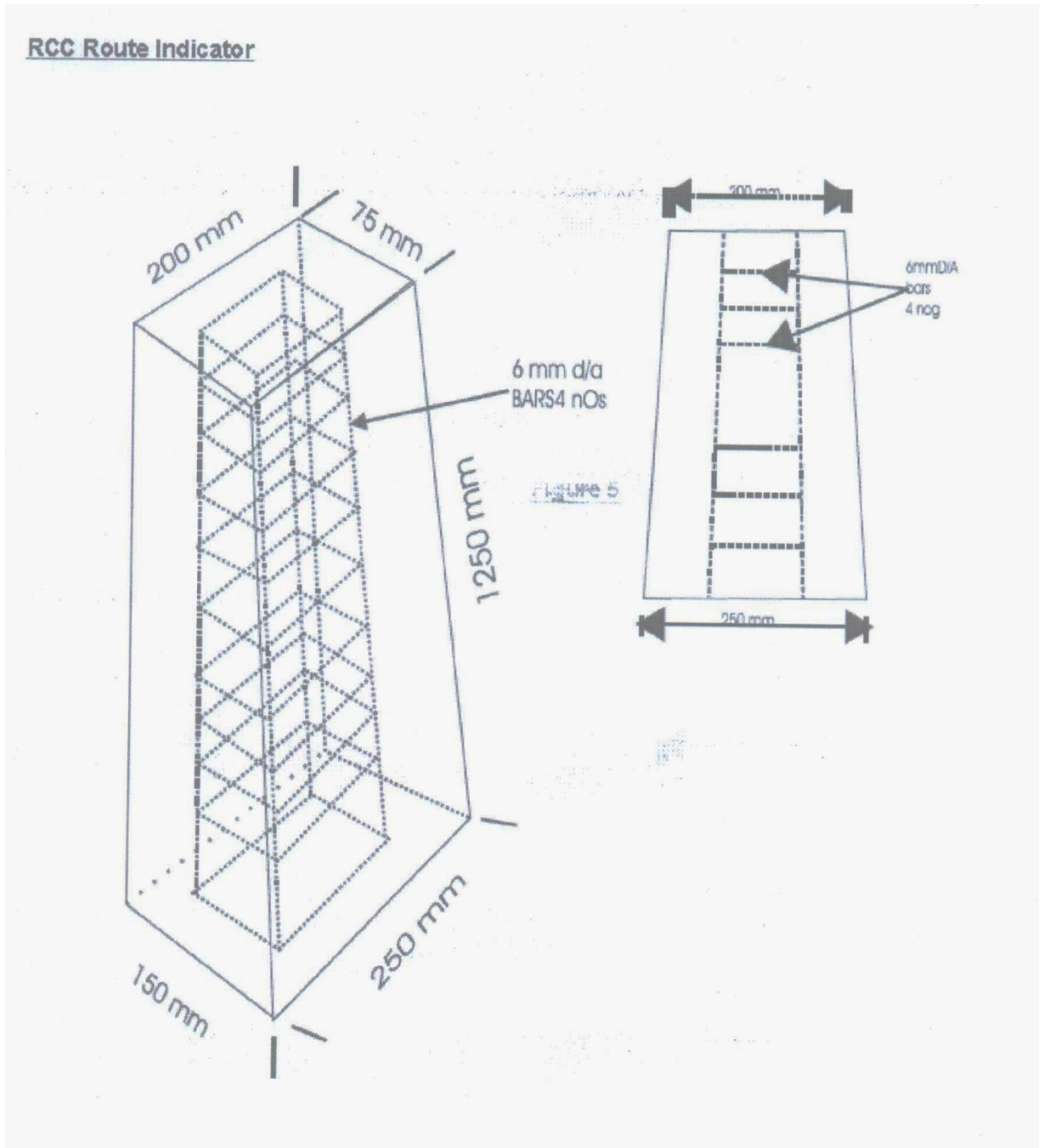
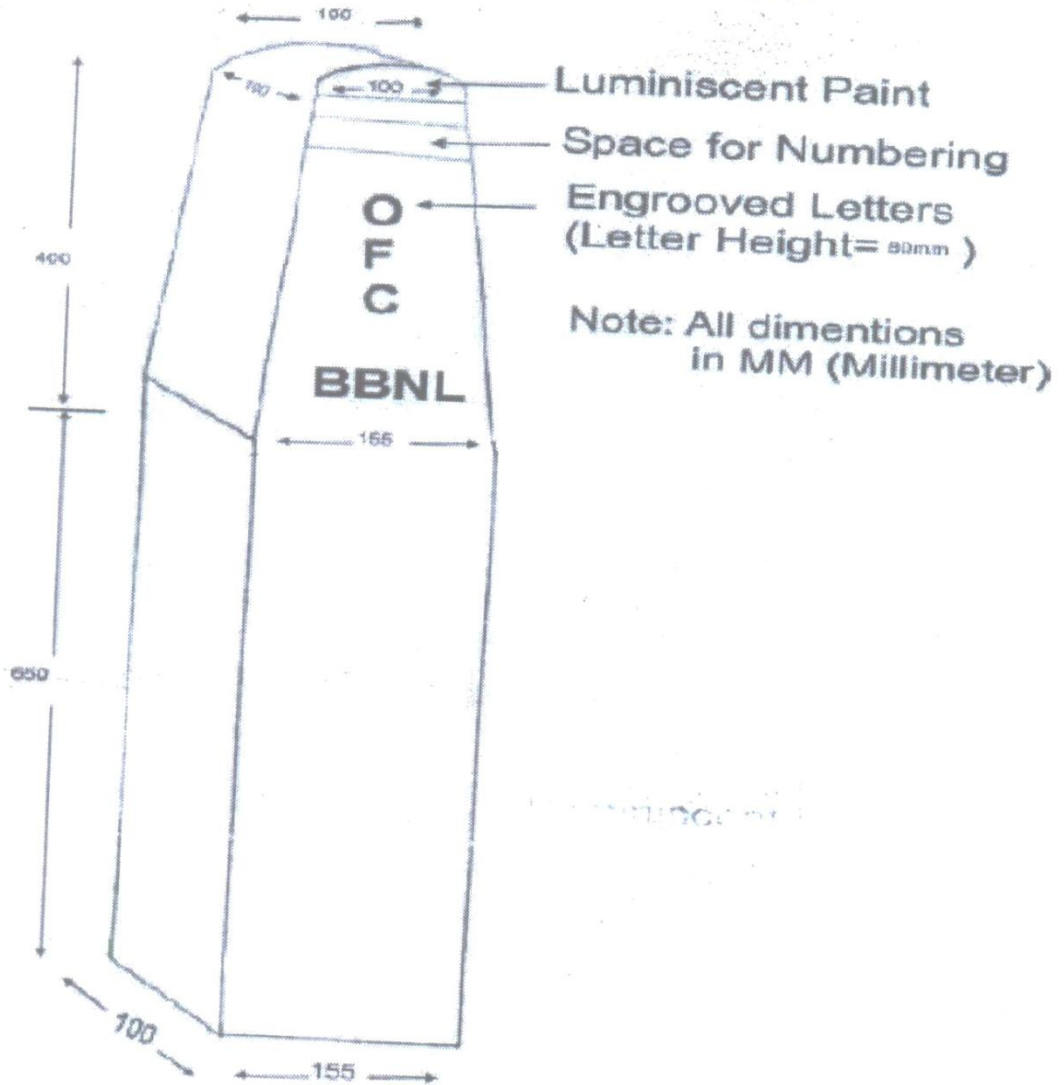

Figure 6

1. Stone OFC Route Indicator



Route indicator will have BSNL painted as per requirement.

Abbreviations

1. DOT : Department of Telecom
2. : Bharat Broadband Network Limited
3. BSNL : Bharat Sanchar Nigam Limited
4. TEC : Telecom Engineering Centre
5. HDPE : High Density Polyethelene
6. DWC Ducts : Double Walled Corrugated Ducts
7. GI pipe: Galvanized Iron Pipe
8. ASTM : American Society for Testing and materials
9. GR : Generic Requirement
10. CACT : Component Approval Centre for Telecom
11. RCC : Reinforced Cement concrete

SECTION IX

MATERIAL SECURITY BOND FORM

Whereas..... (hereinafter called "the contractor") has been awarded the contract of OF cable construction work, as per tender number TENDER NO: : _____ know all men by these presents that We.....of.....having our registered office at _____ (hereinafter called the "the contractor") are bound unto -----(hereinafter called 'the BSNL") in the sum of-----
-----for which payment will and truly to be made of the said BSNL, the bank binds itself, its successors and assigns by these presents.

THE CONDITIONS of the obligation are :

1. If the contractor is unable to keep stores issued to him, properly, i.e. the store provided to the contractor, by the BSNL are damaged or
2. The stores issued to the contractor by the BSNL are stolen or
3. The contractor is not able to provide proper account of the stores issued to him/her/them by the BSNL.

We undertake to pay to the BSNL up to the above amount upon receipt of its first witting demand without the BSNL having to substantiate its demand, provided that in its demand, the BSNL will note that the amount claimed by it is due to it owing to the occurrence of one or two or all of three conditions specifying the occurred condition or conditions.

This guarantee will remain in force up to and including one hundred and eighty (180) days after the Period of contract validity, and any demand in respect thereof should reach the bank not latter than the above date.

Signature of the bank

Signature of the Witness
Name of Witness
Address of Witness

SECTION - IX A

**BHARAT SANCHAR NIGAM LIMITED (BSNL) Bilaspur
PERFORMANCE GUARANTEE BOND FORM**

In consideration of BSNL Bilaspur having agreed to exempt
[hereinafter called 'The said Contractor(S)'] from the demand under the terms & conditions of an
agreement/tender No :

_____ made
between and for the (hereinafter
called 'the said agreement') of security deposit for the due fulfillment by the said contractor(s) of the
terms & conditions contained in the said agreement, on production of a Bank Guarantee for
..... We, (name of the Bank) (hereinafter
referred to as "The Bank") at the request of {contractor(s)} do hereby
undertake to pay the BSNL Bilaspur an amount not exceeding against any loss
or damage caused to or suffered of would be caused to or suffered by the BSNL Bilaspur by reason of
any breach of the terms or conditions contained in the said agreement.

2. We (name of the Bank) do hereby undertake to pay the amounts due &
payable under this guarantee without any demur, merely on a demand from the BSNL Bilaspur stating
that the amount claimed is due by way of loss or damage caused to or would be caused to or suffered by
the BSNL Bilaspur by reason of breach of the said contractor(s) of any of the terms or conditions
(contained in the said Agreement or by reason of the Contractor(s)'s failure to perform the said
Agreement. Any such demand made on the Bank shall be conclusive as regards the amount due &
payable by the Bank under this guarantee where the decision of the BSNL Bilaspur in those counts shall
be final & binding on the bank. However, our liability under this guarantee shall be restricted to an
amount not exceeding.

3. We undertake to pay to the BSNL Bilaspur any money so demanded not withstanding any dispute
or disputes raised by the Contractor(s) / supplier(s) in any suit or proceeding pending before any court or
tribunal relating thereto our liability under this present being absolute & unequivocal. The payment so
made by us under this bond shall be valid discharge of our liability for payment thereunder & the
contractor(s) / supplier(s) shall have no claim against us for making such payment.

4. We (name of the bank) further agree that the guarantee
herein contained shall remain in full force & effect during the period that would be taken for the
performance of the said agreement & that it shall continue to be enforceable till
BSNL Bilaspur..... certifies that the terms & conditions of the said
Agreement have been fully properly carried out by the said contractor(s) & accordingly discharges this
guarantee. Unless a demand or claim under this guarantee is made on us in writing on or before the
expiry of 18 Months from the date hereof, we shall be discharged from all liability under this guarantee
thereafter. As per the request from BSNL, Bilaspur authority, the validity period of this Bank Guarantee
will be further extended for the period as specified and intimated.

5. We (name of the bank) further agree with the BSNL
Bilaspur that the BSNL Bilaspur shall have the fullest liberty without our consent & without affecting in

OFC MTC. MARWAHI-PENDRA DISTRICT

any manner our obligations hereunder to vary any of the terms & conditions of the said Agreement or to extend time performance by the said contractor(s) from time to time or to postpone for any time 'from time to time any of the powers exercisable by the BSNL Bilaspur against the said Contractor(s) & to forbear or enforce any of the terms & conditions relating to the said agreement & we shall not be relieved from our liability by reason of any such variation, or extension being granted to the said contractor(s) or for any forbearance, act or omission on the part of the BSNL Bilaspur or any indulgence by the BSNL Bilaspur to the said contractor(s) or by any such matter or thing whatsoever which under the law relating to sureties would, but for this provision, have effect of so relieving us.

6. This guarantee will not be discharged due to the change in the constitution of the Bank or the Contractor(s)/Supplier(s).

7. We (name of the bank) lastly undertake not to revoke this guarantee during its currency except with the previous consent of the BSNL Bilaspur in writing.

8. Not with standing anything mentioned here in above our liability under this guarantee is restricted to Rs. _____/- (Rs. _____/-) & this guarantee is valid up to _____. We shall be released & discharged from all liabilities here under unless written claim for payment under this guarantee is lodged on expiry of the guarantee i.e. on or before _____ irrespective of whether or not the original guarantee is returned to us.

Dated the day of

for

(Indicate the name, detailed address of the Bank with Tel. No.)

SECTION - X

AGREEMENT

Tender No. : _____
(The successful Bidder shall have to execute the following agreement)

This agreement made on this _____ day of (months) _____
(year) _____ between M/s _____
_____ herein after called "The contractor" (Which expression shall unless excluded by or repugnant) to the context, include its successors, heir, executors, administrative representative and assignee) of the one part & the representative of BSNL on behalf of _____ on the other part.

Whereas the contractor has offered to enter into contract with the said BSNL for the execution of work of trenching & pipe laying of cable pulling of cable splicing and termination, preparation of joint chambers, fixing, painting and sign writing of route/joint indicators and other associated works in GMTD Bilaspur on the terms and conditions herein contained and the rates approved by the BSNL (copy of rates annexed) have been duly accepted and where as the necessary security deposits have been furnished in accordance with the provisions of the tender document and whereas no interest will be claimed on the security deposits.

Not these presents witness and it is hereby agreed and declared by and between the parties to these presents as follows.

1. The contractor shall, during the period of this contract that is to say from to or completion of work for Rs _____ (in words) _____ whichever is earlier or until this contract shall be determined by such notice as is hereinafter mentioned, safely carryout, by means of labours employed at his own expenses and by means of tools, implements and equipment etc. to be supplied by him to his labour at his own expenses, all trenching pipe laying cable pulling cable splicing, joint chamber preparation fixing painting and sign writing of route indicators and other associated works as described in tender documents (annexed to the agreement), when the BSNL or GMTD Bilaspur or any other personal authorized by GMTD Bilaspur in that behalf require . It is understood by the contractor that the quantity of work mentioned on the schedule is likely to change as per actual requirements as demanded by exigencies of service.
2. The NIT (notice inviting tender), W-1-1/NIT/Tender/GMTD-BIL/21-22/133 DatedBid documents (Qualifying and Financial), letter of intent approved rates, annexed hereto and such other additional particulars, instruction, drawings, work orders as may be found requisite to be given during execution of the work shall be deemed and taken to be an integral part of the contract and shall also be deemed to be included in the expression "The agreement" or "the contract" wherever herein used.
3. The contractor shall also supply the requisite number of workmen with means & materials as well as tools, appliances, machines, implements, vehicles for transportation, cartage etc. required for the proper execution of work within the time prescribed in the work orders.

4. The contractor hereby declares that nobody connected with or in the employment of the BSNL of telecommunications / DTS is not / shall not ever be admitted as partner in the contract.
5. The contractor shall abide by the terms and conditions, rules, guidelines, construction practices, safety precautions etc. stipulated in the tender documents including any correspondence between the contractor and the BSNL having bearing on execution of work and payments of work to be done under the contract.
6. Any damage caused during transporting of materials. The contractor will be responsible and he is liable to make full payment of damaged material
7. The contractor shall have to follow all the labour laws
8. Copy of paid challan of EPF & ESI must be submitted with bill
9. Copy of Attendance register & wage slip or ECR must be submitted with bill
10. The contractor shall provide all safety measures as per Govt. safety act rules. BSNL will not entertain any claim by way of compensation
14. SD :- 10% amount will be deducted from each bill
15. MSD Deposit :-
16. PSD Deposit:-

In witness where of the parties presents have here into set their respective hands and seals the day and year in _____

Above Written:

Signed sealed & Delivered by
the above named contractor in
the presence of .

Witness:

- 1.
- 2.

Signed & executed on behalf
by

Witness:

- 1.
- 2.

In -----

SECTION XI

Letter of Authorization for attending Bid Opening Event.

(To be typed preferably on letter head of the company)

Subject: Authorization for attending Bid opening

I/ We Mr. /Ms. have submitted our bid for the tender no. in respect of

..... (Item of work) which is due to open on (date) in the *AGM (NP-CFA), 2nd Floor, Telephone Exchange Near Agrasen Chowk Bilaspur - 495001*

We hereby authorize Mr. / Ms. & Mr. / Ms..... (Alternative) whose signatures are attested below, to attend the bid opening for the tender mentioned above on our behalf.

..... Signature of the Representative

Signature of Bidder/ Officer authorized to sign Name of the Representative on behalf of the Bidder

..... Signature of the alternative Representative

Name of the alternative Representative above Signatures Attested

- Note 1:** Maximum two representatives will be permitted to attend the Bid opening
- 2. Permission for entry to the hall where bids are opened may be refused in case authorization as prescribed above is not received.

SECTION XII
PROFORMA OF POWER OF ATTORNEY
(Refer Clause 14.3 of Section-4 Part A)
Non-Judicial Stamp
POWER OF ATTORNEY

Be it known all to whom it concern that :-

- 1. Shri/Smt./Ku _____ S/o / W/o / D/o _____ residing at _____
- 2. Shri/Smt./Ku _____ S/o / W/o / D/o _____ residing at _____
- 3. Shri/Smt./Ku _____ S/o / W/o / D/o _____ residing at _____

I, the Proprietor/We all the Partners/Directors of M/s _____ (Name& Address) hereby appoint
 Shri/Smt./Ku. _____ s/o / w/o / d/o _____
 residing at _____ as my/our Attorney to act
 in my/our name and on behalf and sign and execute all documents/agreements binding the firm for all contractual
 obligations (including references of cases to arbitration) arising out of contracts to be entered into by the firm with
 the GMTD, ----- in connection with their Tender Enquiry No.

dated _____ for the supply of _____ due for opening on _____

_____. In short he is fully authorized to do all, each and everything requisite for the above
 purpose concerning M/s _____. And I/We hereby
 agree to confirm and ratify his all and every act of this or any documents executed by my/our said Attorney within
 the scope of the authority hereby conferred on him including references of cases to arbitration and the same shall
 be binding on me/us and my/our firm as if the same were executed by me/us individually or jointly.

Witness (with Address) 1.Name _____ Sign. _____ (Address _____) 2.Name _____ Sign. _____ (Address _____) 3.Name _____ Sign. _____ (Address _____)	Signature of the Proprietor/Partners/Directors 1.Name: _____ Sign. _____ 2.Name: _____ Sign. _____ 3.Name: _____ Sign. _____
--	---

Accepted
 (Name & Signature of Signatory of Tender Offer of the firm)
 (with Designation, Address, Phone No., Mobile No. & Email)

A T T E S T E D
 Notary Public
 (Signature with Official Seal)

OR
 R E G I S T E R E D
 Before

(SUB – REGISTRAR) (of concerned State)
 Signature with Official Seal

(Note :-Kindly refer Clause 11.3 of Section-4 Part-A for compliance same is reiterated as :-

(i) The Power of Attorney should be submitted and executed on the non-judicial stamp paper of appropriate value as prevailing in the respective states(s) and the same be EITHER attested by a Notary Public OR registered before Sub-Registrar of the states(s) concerned.

(ii) The said Power of Attorney be executed by a person who has been authorized by the Board of Directors of the bidder in this regard, on behalf of the Company/Institution/Body corporate .Copy of the Board Resolution / authorization shall also be submitted along with POA

(iii) In case of the bidder being a firm, the said Power of Attorney should be executed by all the partner(s) in favour of the said Attorney.)

SECTION - XIII

RATES OF EMPTY CABLE DRUMS

These are the rates of the empty cable drums which have to be deducted from contractor's bills as per tender document.

SI.No.	Size of drum	Rate of disposal
1.	Optical Fiber cable drums.2F/4F/12F/24F/96F	Rs. 300/-per cable drum

Note : These are fixed rates and no variation shall be acceptable from these rates during bidding.

SECTION-XIV-A

REGARDING NEAR RELATIVES (UNDERTAKING-I)

“I S/o.....

..... resident of hereby certify that none of my near relative(s) and none of near relative(s) of proprietor/ partner(s)/ director(s) of company is/ are employed in BSNL unit as defined in the tender document at **clause A.1.y of section- 4 Part A**. In case at any stage, it is found that the information given by me is false/ incorrect, BSNL shall have the absolute right to take any action as deemed fit/without any prior intimation to me”.

SIGNATURE OF BIDDER: _____

NAME OF BIDDER: _____

Seal of the Tenderer

SECTION-XIV -B

DECLARATION REGARDING BLACK LISTING / DEBARRING FROM TAKING PART IN THE GOVT. TENDERS BY BSNL (UNDERTAKING-II)

(To be duly signed by the bidder with seal invariably)

I/We _____

Proprietor/Partner/Director(s) of M/s. _____

has/ have not been blacklisted or debarred in the past by DOT/BSNL/MTNL or any other Government /Semi Government BSNL from taking part in the Government tenders.

In case above information is found false I/we am/are fully aware that the tender/contract will be rejected/cancelled by the General Manager Telecom. District, *Bilaspur* and EMD/SD shall stand forfeited along with any suitable action as deemed fit.

Signature

Seal of the firm

Place

Capacity in which is signed

Date

Name and Address of the firm

SECTION-XIV -C

PAYMENT INSULATION (UNDERTAKING-III)

I/We undertake that I have sufficient capital resources to execute the scope of this tender and will make due payment to our firms labour / employees assigned to execution of the tender of Bilaspur SSA (BSNL) as per laws every month insulating it from payments from BSNL. I/We also **under take** to perform in faithful & efficient manner the work of this tender without linking it to payments from BSNL.

Signature of Bidder

Name of the Bidder
(Capacity in which signing)

Station:

Date:

SECTION – XIV-D

UNDERTAKING and DECLARATION (UNDERTAKING-IV)

Understanding the terms and condition of Tender and Specification of work

A) Certified that:

1. I/ We _____, have read and agree with all the terms and conditions, specifications included in the tender documents and offer to execute the work at the rates quoted by us in the tender form.
2. If I/ We fail to enter into the agreement and commence the work in time, the EMD/ SD deposited by us will stand forfeited to the BSNL.

B) The tenderer hereby covenants and declares that:

1. All the information, Documents, Photo copies of the Documents/ Certificates enclosed along with the Tender offer are correct.
2. If anything is found false and/or incorrect and/or reveals any suppression of fact at any time, BSNL reserves the right to debar our tender offer/ cancel the LOI/ Award of Work/ work order if issued and forfeit the EMD/ SD/ Bill amount pending with BSNL. In addition, BSNL may debar the contractor from participation in its future tenders.

Date: _____

Signature of Tenderer

Place: _____

Name of Tenderer _____
Along with date and Seal

SECTION - XIV –E

Clause by Clause compliance (UNDERTAKING-V)

I/Wehereby undertake that all the terms and conditions as per Tender Enquiry No..... for theare acceptable to us. We have nil deviation from bid stipulation of this tender document.

Place :.....

Signature of tenderer/Authorized Signatory.....

Date :

Name of the Tenderer.....

Seal of the Tenderer

SECTION – XV
BID DOCUMENT
(FINANCIAL BID)

E-Tender for OFC Maintenance in Marwahi-Pendra District
under Bilaspur SSA.

Tender No. T-133/Ofc-Mtc./Marwahi/21-22/20

Dated – 24.07.2021

NIT No. W-1-1/NIT/Tender/GMTD-BIL/21-22/133

Dated – 24.07.2021

OFFICE OF THE GENERAL MANAGER TELECOM
.....

SECTION – XV
Financial Bid

To

The AGM (NP-CFA)
O/o GMTD BSNL Bilaspur

NIT No. :- W-1-1/NIT/Tender/GMTD-BIL/21-22/133

Dated – 24.07.2021

SN	Item / Work	UNIT	Qty	Rate (In INR) in Fig	Rate in Words
1	Through rate for excavating trenches up to a depth of 165 cms. Including laying of HDPE/PLB pipe, and back filling the excavated trenches in the original shape after laying the HDPE/PLB pipe with or without protection	PER METER	1500		
2	Laying of additional HDPE/PLB pipes /Coils, coupled with HDPE sockets and drawing 6 mm PP rope.(Department will supply HDPE pipes , HDPE sockets, PP rope, End Caps) in same trenches	PER METER	1500		
3	Road/Rail crossing through horizontal boring method and inserting 65/40 mm dia GI pipes and pushing HDPE/PLB pipes/coils inside and drawing 6 mm PP rope(Department will supply G.I. Pipes in lengths of approx. 6 M, HDPE Pipes/ Coils and PP Rope)	PER METER	50		
4	Laying full round RCC Pipes in trenches with HDPE/PLB Pipes/coils inside and drawing PP rope	PER METER	50		
5	Laying Half round RCC Pipes in trenches with HDPE/PLB Pipes/coils inside and drawing PP rope.	PER METER	50		
6	laying OF cable (Low count 2F/ 4F/ 6F) Overhead/manual pulling	PER METER	1000		
7	laying OF cable (12 F and above) Overhead/manual pulling	PER METER	3000		
8	Digging of PITS of Size 165 cms. X 120 cms. X 120 cms., for opening & splicing of joint (All materials required for the work shall be arranged by the contractor)	PER PIT	200		
9	Digging of PITS for Fault Location mechanically using Earth Excavation machines	Per HR	75		
10	Pulling of O F Cable all sizes by blowing method	PER METER	1500		
11	Splicing OF cable (Low count 2F/ 4F/ 6F) in joints/termination department will supply jointing material, splicing machine, tool kit, OTDR and contractor will supply vehicle	PER JOINT	15		
12	Splicing OF cable (Low count 2F/ 4F/ 6F) in joints/termination department will supply only jointing material, and contractor shall arrange splicing machine, tool kit, OTDR and vehicle	PER JOINT	25		

OFC MTC. MARWAHI-PENDRA DISTRICT

13	Splicing OF cable (Low count 2F/ 4F/ 6F) in joints/termination department will supply jointing material, splicing machine, tool kit, OTDR and vehicle	PER JOINT	25		
14	Splicing OF cable (12 F and above) in joints/termination department will supply jointing material, splicing machine, tool kit, OTDR and contractor will supply vehicle	PER 12 FIBER	10		
15	Splicing OF cable (12 F and above) in joints/termination department will supply only jointing material, and contractor shall arrange splicing machine, tool kit, OTDR and vehicle	PER 12 FIBER	150		
16	Splicing OF cable (12 F and above) in joints/termination department will supply jointing material, splicing machine, tool kit, OTDR and vehicle	PER 12 FIBER	50		
17	Digging of pits 1 meter on each manhole/joint chamber for supply and fixing of route/joint indicator, fixing and concreting of route/joint indicator, Painting and sign writing of route/joint indicators (With Supply of material)	PER INDICATOR	50		
18	Horizontal boring by HDD method with bore 225 mm dia ,inserting maximum 3 HDPE/3 PLB pipes (165 cm depth)	PER METER	150		
19	Cement Concrete 20x20 cm including PLB/GI pipe and drawing pp rope (all materials will arrange by contractor)	PER METER	100		
20	Digging of Pits for jointing chamber, fixing of pre-cast RCC chamber, filling of RCC chamber with clean sand, placing of pre-cast RCC slab on RCC chamber, and back filling of jointing pit (The BSNL will supply Pre-cast RCC Chamber with cover. (All other material arrange by contractor)	EACH	2		
21	Digging of Pits for jointing chamber, fixing of pre-cast RCC chamber, filling of RCC chamber with clean sand, placing of pre-cast RCC slab on RCC chamber, and back filling of jointing pit. (The contractor shall arrange all materials required for the work)	EACH	2		

Note :-

1. Rate should be inclusive of labour charges, transportation & all taxes / duties applicable in state/central govt. and public bodies excluding GST.
2. The rate should be quoted clearly in figures and in words without correction.
3. In case of difference between the rate quoted in words and Figures the rates quoted in words will prevail.
4. For the purpose of evaluation, the TEC will obtain the grand total by multiplying the rates quoted for different items with the approximate quantities mentioned for those items in the financial bid. The lowest grand total will be treated as L-1
5. Please submit **Financial Bid , Online only with signed PDF and .xls format both.**

We agree to abide by this Bid for a period of 180 days from the date of opening of techno commercial bid and it shall remain binding upon us and may be accepted at any time before the expiry of that period.